

4D RADAR - S32R41+TEF82XX DEVELOPMENT PLATFORM OVERVIEW

Vincent Guan
Senior Application Engineer
APRIL 2023



SECURE CONNECTIONS
FOR A SMARTER WORLD

PUBLIC

NXP, THE NXP LOGO AND NXP SECURE CONNECTIONS FOR A SMARTER WORLD ARE TRADEMARKS OF NXP B.V.
ALL OTHER PRODUCT OR SERVICE NAMES ARE THE PROPERTY OF THEIR RESPECTIVE OWNERS. © 2023 NXP B.V.



S32R41 - AUTOMOTIVE 4D RADAR PROCESSOR

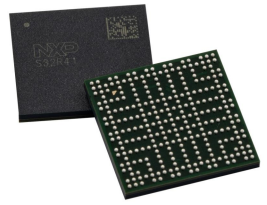

- S32R41 is a radar microprocessor unit (MPU) dedicated to advanced 77 GHz radar applications. The architecture features Arm® Cortex®-A53 and Cortex-M7 cores which are combined with dedicated radar processing accelerators to create an optimal radar processing chain. It is designed to target automotive, industrial and consumer radar applications.
- The comprehensive feature set enables the S32R41 family to meet the requirements of advanced high-resolution corner and front radar applications. The high-performance processing in combination with Dual MIPI CSI interfaces and 8MB of local SRAM enable high resolution radar systems that are required for L2 Autonomous driving applications and beyond.
- The S32R41's architecture is part of [NXP's scalable radar portfolio](#). This enables scalable software reuse and reduced development complexity.

High Performance Safe Compute	<ul style="list-style-type: none"> • Arm Cortex-A53 @800 MHz • 2x Arm Cortex-M7 @400 MHz with lockstep core configuration (ASIL D capable)
Radar Processing Acceleration	<ul style="list-style-type: none"> • SPT 3.5 @600 MHz with integrated DSP
Integration with NXP Radar MMIC's	<ul style="list-style-type: none"> • 2x MIPI CSI2 to connect to NXP TEF82xx
Memory Capacity for Demanding Radar Applications	<ul style="list-style-type: none"> • 8 MB SRAM with ECC
Future Proof Security	<ul style="list-style-type: none"> • ISO21434 compliant product development • In-field updatable Hardware Security Engine (HSE) with comprehensive feature set
Designed with Safety in Mind	<ul style="list-style-type: none"> • ISO26262 SEooC ASIL B(D)
Connected and Scalable	<ul style="list-style-type: none"> • 2x Ethernet interfaces: 1x RGMII (1000 Mbit/s), 1x RMII (100 Mbit/s) • 2x FlexCAN with FD
Full Grade1 Temperature Range Operation	<ul style="list-style-type: none"> • -40 °C to 150 °C (Tj) AEC-Q100 Grade-1
Other Features	<ul style="list-style-type: none"> • 1x SAR ADC with 8 channels
Product Longevity Program	<ul style="list-style-type: none"> • This product is included in the NXP Product Longevity program ensuring a stable supply of products for your embedded designs

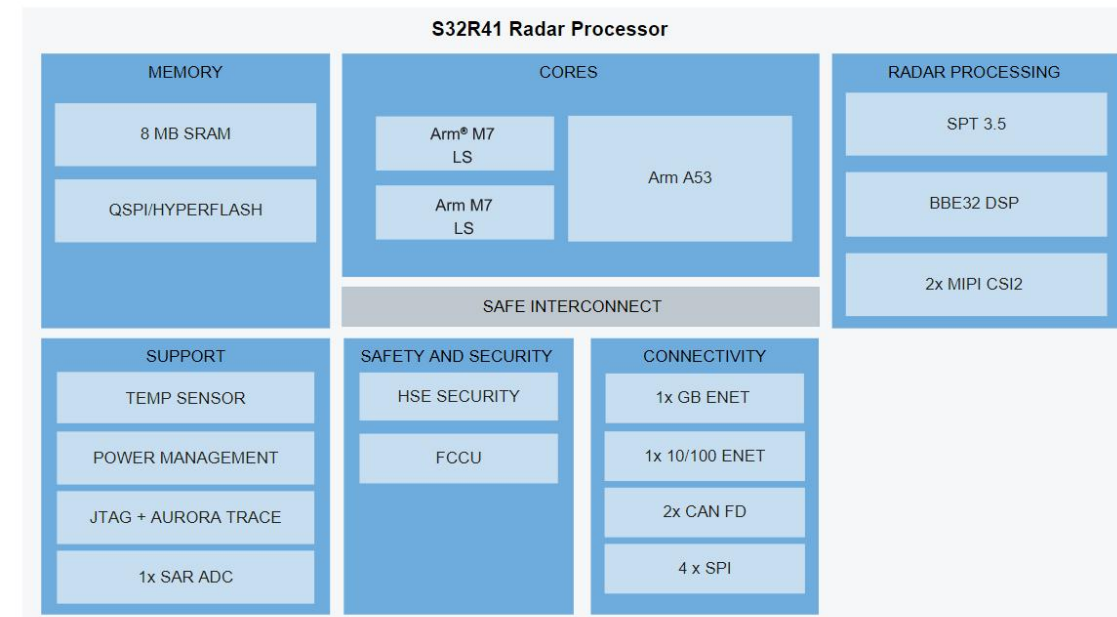

TEF82XX - FULLY INTEGRATED 77 GHZ RFCMOS AUTOMOTIVE RADAR TRANSCEIVER

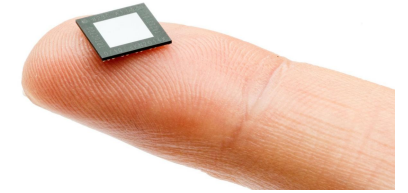

- The TEF82xx RFCMOS automotive radar transceiver is a high performance single-chip, low power automotive FMCW radar transceiver covering the full automotive radar frequency band from 76 GHz to 81 GHz. Entry NCAP sensor all the way up to autonomous driving L2+ sensors and beyond are enabled by this 2nd generation scalable transceiver supporting short, medium and long-range radar applications including cascaded high resolution imaging radar. This fully integrated RFCMOS chip contains 3 transmitters, 4 receivers, ADC conversion, phase rotator and a low-phase-noise VCO.
- TEF82xx is an ISO 26262 compliant device targeting ASIL Level B, which is optimized for fast chirp modulation and is fully compatible with NXP S32R29x, S32R41x and S32R45x radar microcontrollers and processors.

Highly Integrated Transceiver	<ul style="list-style-type: none"> Integrates up to 3 transmit and 4 receive channels Integrates VCO, PLL and ADCs BPSK and QPSK supported 6-bit phase rotator MIMO Radar operation supported Supports FMCW Radar applications Optimized for Fast Chirp Modulation
Wide Frequency Range	<ul style="list-style-type: none"> Operates in 76 GHz to 81 GHz band
Wide Bandwidth	<ul style="list-style-type: none"> Flexible chirp bandwidth up to 5 GHz Effective bandwidth up to 4 GHz
High Performance	<ul style="list-style-type: none"> Enhanced RF performance with power output of 13.5 dBm Low Noise figure: 11.5 dB Low phase noise: -95 dBc/Hz at 1 MHz
Very Low Power	<ul style="list-style-type: none"> 1.5 W power dissipation for a 2Tx channel 50% duty cycle operation
Scalable Applications	<ul style="list-style-type: none"> Supports short to long range applications Cascaded imaging radar supported
Small Package	<ul style="list-style-type: none"> e-WLB exposed die package for excellent thermal performance Very small footprint of 7.5 mm x 7.5 mm
Flexible Host Interfaces	<ul style="list-style-type: none"> CSI-2-DPHY and LVDS MCU interface for data transfer Full-duplex SPI for control and monitoring
ASIL B Functional Safety	<ul style="list-style-type: none"> Developed in accordance with ISO26262 SEoOC methodology. Supporting ASIL B applications Built-in functional safety monitoring circuit
Automotive Quality	<ul style="list-style-type: none"> AEC-Q100
Wide Automotive Temperature Range	<ul style="list-style-type: none"> -40 to 135°C junction temperature

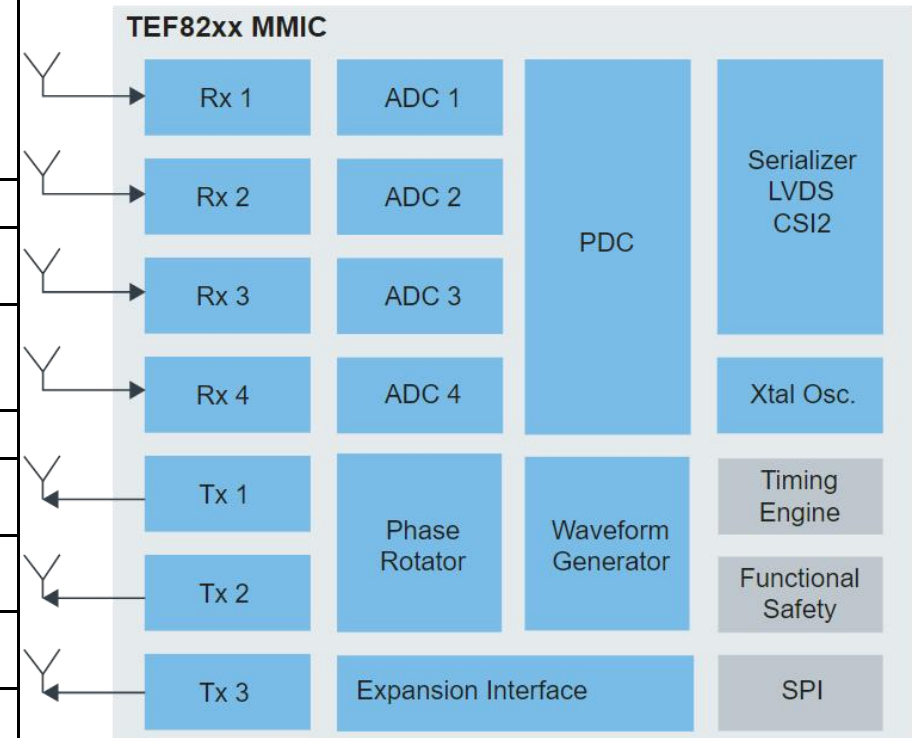

SOFTWARE ENABLEMENT FOR S32R41 AND TEF82XX

Tools

1. S32 Design Studio for S32 Platform
Pin MUX tool, Clock tool, peripheral tool, Configuration tool, S32Debugger
2. Radar extension package
3. BBE Add-on package
4. SPT Model-based Design Tool
5. S32 Flash Tool

Reference SW

1. TCP/IP Stack
2. NXP Platform Integration SW Examples
3. Zephyr OS
4. **S32R41+TEF82xx Development Platform**

Standard SW

1. RADAR SDK
Enablement for radar signal acquisition and processing
2. Real Time Drivers (RTD) for AUTOSAR[®]/Non-AUTOSAR applications, including SBC devices (PMIC, CAN trcv, ETH trcv)
3. Security FW
4. Safety Peripheral Drivers (SPD)
5. Inter-Platform Communication Framework (IPCF)
6. NXP RTOS

Premium SW

1. Premium Radar SDK
Advanced radar processing algorithms
2. Premium Security FW
Custom OEM FW available on request
3. Premium Safety SW
 - Safety Software Framework (SAF)
 - Structural Core Self Test (SCST A53)
4. SPT Assembler Safety Qualification Kit

S32R41+TEF82XX DEVELOPMENT PLATFORM OVERVIEW

- The [S32R41+TEF82xx Development Platform](#) is designed for enabling users to start Radar development quickly and easily by providing a S32R41+TEF82xx hardware platform and an example software project integrating NXP software components:
 - S32R41 A53 Zephyr BSP
 - S32R41 Radar SDK (RSDK)
 - S32R41 Real Time Drivers (RTD)
 - Inter-Platform Communication Framework (IPCF)
 - Safety Software Framework (SAF)
 - NXP Real Time Operation System (RTOS)

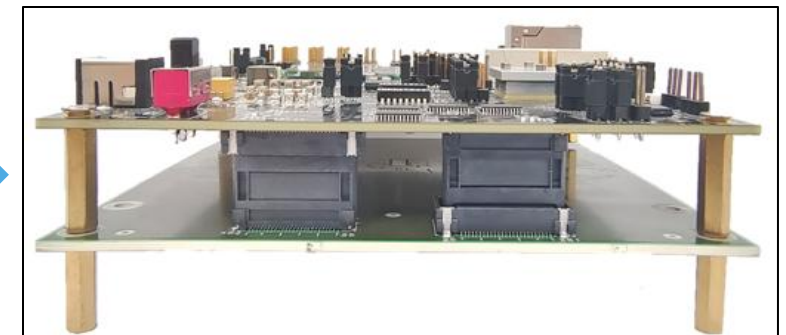
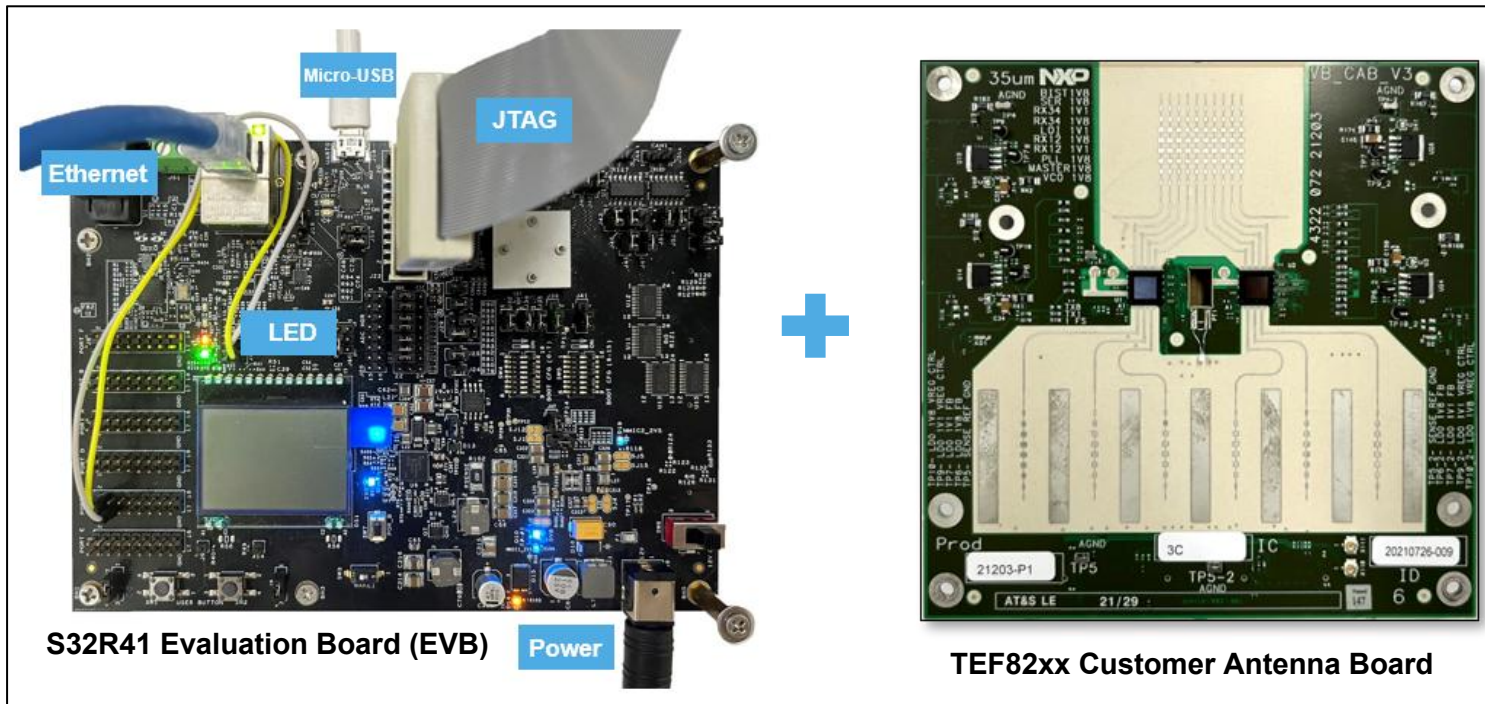

BLOCK DIAGRAM – V1.1 RELEASE

S32R41 Standard Software S32R41 Premium Software Release contents 3rd Party

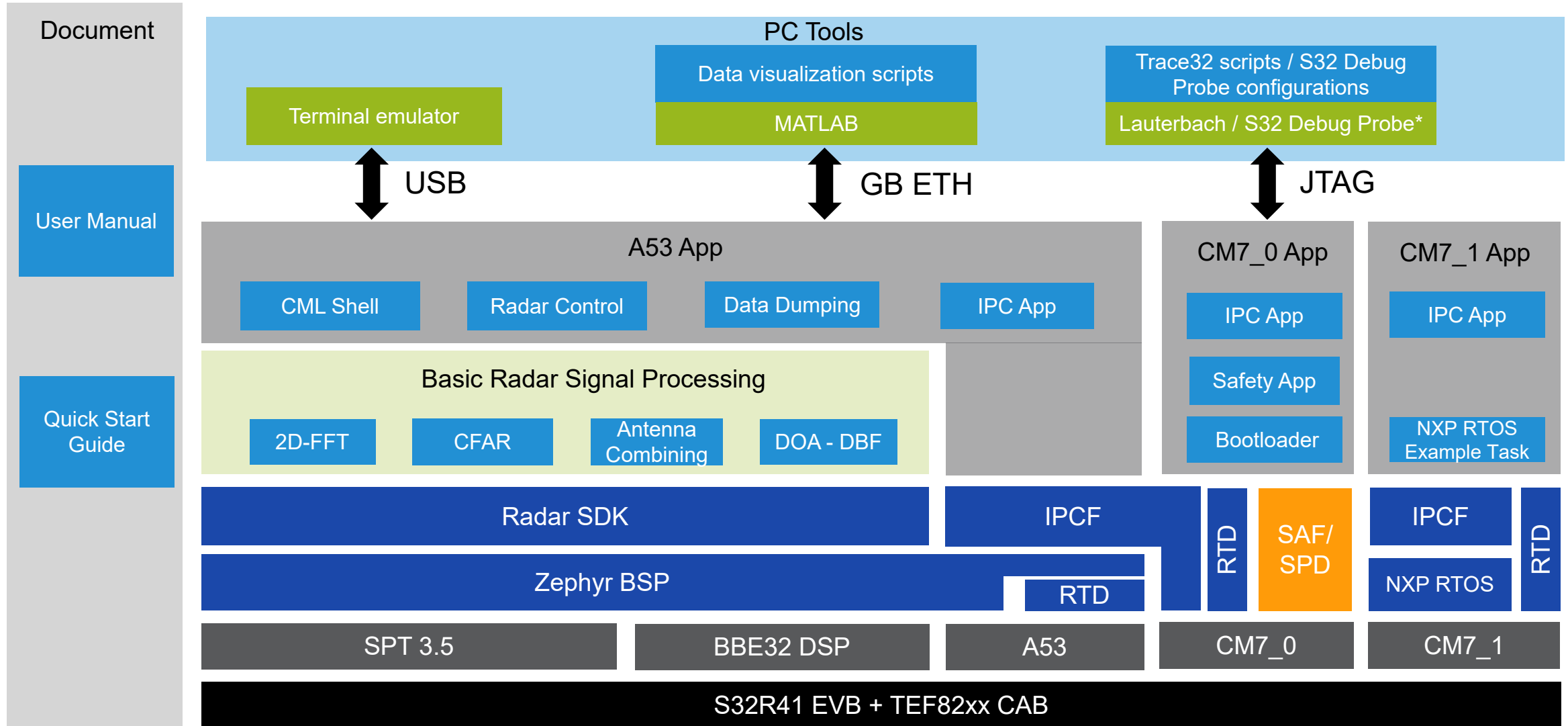

* S32 Debug Probe is a NXP product

KEY FEATURES

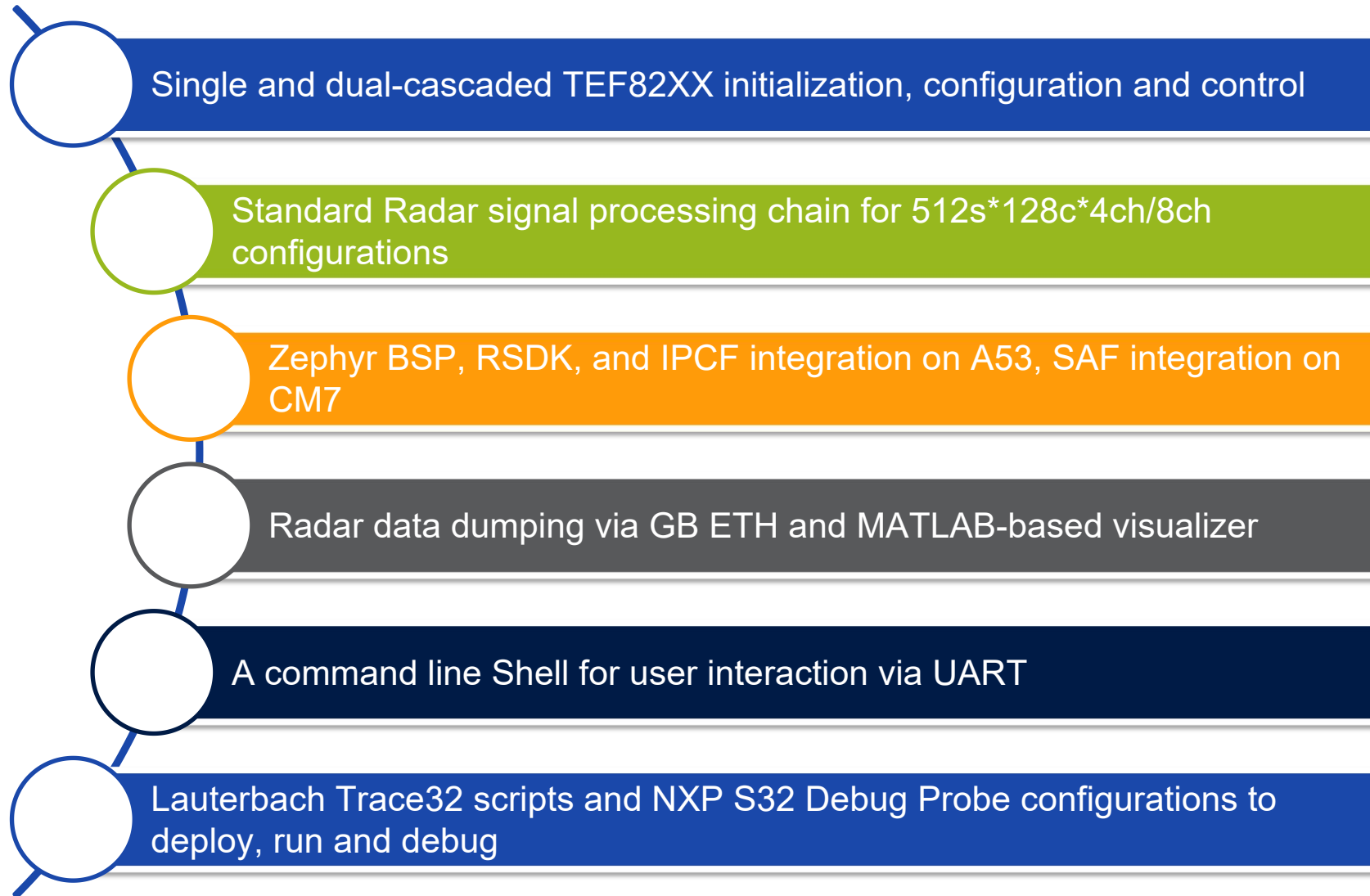

SOFTWARE REQUIREMENTS

Title	Version	Description	Download
S32 Design Studio	SW32R41_S32DS_3.5_D2207	Based on the Eclipse and integrates the Eclipse IDE, GCC, GDB. Used to build project files and debug.	S32R41 Radar Processor NXP Semiconductors
S32R41 support in S32 Design Studio	SW32R41_S32DS_3.5_D2207	Development Package, contains gcc toolchain and generic S32R41 processor support.	
	SW32SAF85xx_S32R41_RTD_4.4_0.9.0_HF01_D2211	S32R41 Real Time Drivers, contains IVT Tool for S32R41.	
	SW32R41_S32DS_RADAR_1.0.0.EAR5_D2208	Radar Extension package, contains SPT assembler for S32R41	
	SW32R41_S32DS_BBE32_1.0.0.EAR5_D2208*	BBE32 DSP Add-On Package, contains Xtensa BBE32 toolchain for S32R41	
	S32R41_SPD_0.9.0 (or S32R41_SAF_0.9.0)	Safety Peripheral Drivers (Safety Software Framework) for S32R41	
	SW32SAF85_S32R41_XJA11XX_ETH_PHY_4.4_1.0.1_D2211	NXP XJA11XX Ethernet PHY Real Time Drivers for S32R41	
	S32R41_IPCF_0.9.1_D2301	Inter-Platform Communication Framework (IPCF) for S32R1	
	SW32R41_RTOS_4_4_CD2_0_8_1_HF2_D2212	NXP RTOS (AUTOSAR compliant) for S32R41	
S32R41 ZEPHYR BSP	SW32R41_AZ_2.7.2_0.9.0_HF01_D2302	NXP Zephyr RTOS BSP for S32R41.	
S32R41 Radar SDK	SWS32R41_Radar_SDK_0_9_0_D2211	Radar SDK software for S32R41.	
Trace32	Software Version: N.2021.09.000140094	Lauterbach software for debugging	www.lauterbach.com
	Trace32 PowerView Update 150201 or later		
TeraTerm or PuTTY	Any	Serial terminal emulator program for host PC.	www.teraterm.org www.putty.org
MATLAB	R2021a equipped with Instrument Control Toolbox	Radar Visualizer scripts are only tested on MATLAB R2021a	www.mathworks.com

*The BBE32 DSP toolchain is added to the S32 Design Studio by installing this add-on

- S32DS BBE32 DSP add-on package is available from NXP software portal upon request.
- The package integrates the Xtensa Software Developers Toolkit (Certified ISO 26262 Compliant Compiler Toolchain)
- The license for the toolkit is available to order from NXP, please contact your NXP representative.

SUPPORTED DEBUGGER

Debugger Options	Version	Description	Download/Order
Lauterbach	Host interface module: LA3500 Debug cable: LA7843 LA-3743: license for Cortex-A/R (ARMv8 32/64-bit). LA-7844: license for Cortex-M (ARMv7/8 32-bit).	Host PC software to control Lauterbach debugger. Licensing requirements: ARMv8-A/R, Cortex-M, XTENSA	www.lauterbach.com
NXP S32 Debug Probe	N/A	S32 Debug Probe enables NXP target system debugging via a standard debug port while connected to a developer's workstation via Ethernet or USB. S32 Debug Probe may also be referred to by industry-standard terms such as a probe, JTAG probe, JTAG emulator or target probe.	S32 Debug Probe NXP Semiconductors



- Highlights**
- USB3.0 interface to all hosts
 - Connects to target via TRACE32 Debug Cable or TRACE32 CombiProbe, which provide debug support for many core architectures, such as ARC, Arm Cortex, Power Architecture, RISC-V, TriCore, Xtensa
 - Trigger connector to send and receive trigger pulses



Debugger for Cortex-A/R (Armv7 32-bit)
Supports Armv7-A/R based Cortex-A and Cortex-R 32-bit cores

supports 5-pin standard JTAG, cJTAG and Serial Wire Debug Port (0.4 V - 5 V)

includes software for Windows, Linux and MacOSX

requires Power Debug Module

cJTAG and SWD require
Power Debug Interface USB 2.0/USB 3.0,
Power Debug Ethernet, PowerTrace, Power Debug II
or PowerDebug PRO

Lauterbach



NXP S32 Debug Probe

LIVE DEMONSTRATION

- Hardware Setup

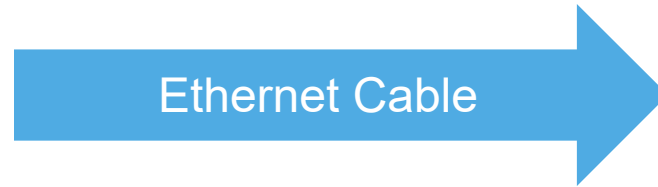
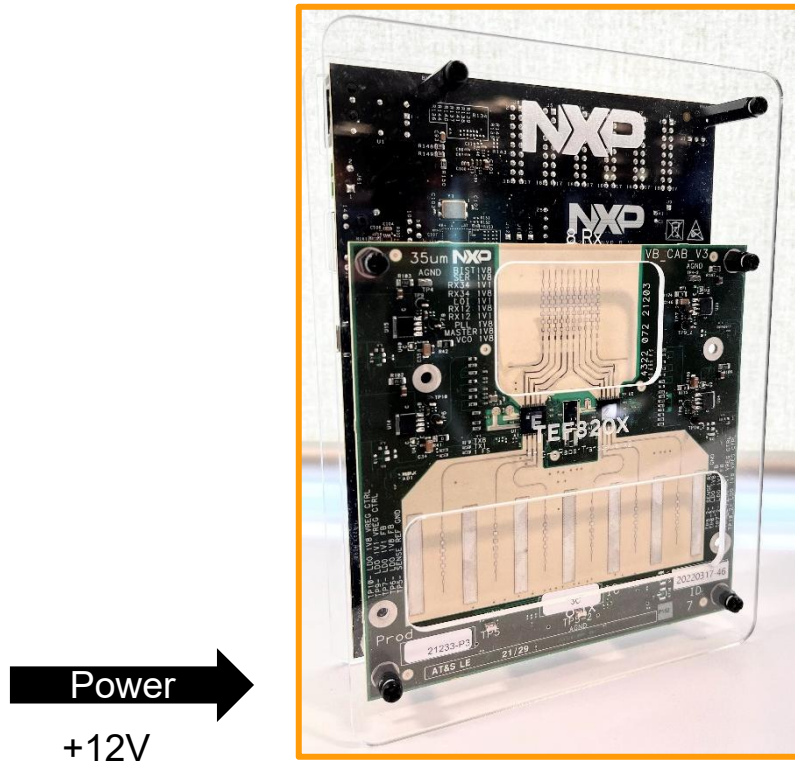

PC

- *MATLAB* – Visualize Radar data
- *Terminal emulator* – Interact with Radar board



TECHNOLOGY SHOWROOM

JOURNEYS BY DESIRED ENGAGEMENT

- Self-guided tour
- Live-streaming at set times
- Guided tours

60+ VIRTUAL DEMOS

- Focus on system solutions
- Set up along NXP verticals

JOURNEYS BY DESIRED FOCUS

- Low Power Innovations
- Advanced Analog
- Connectivity
- Edge & AI/ML
- Safety & Security

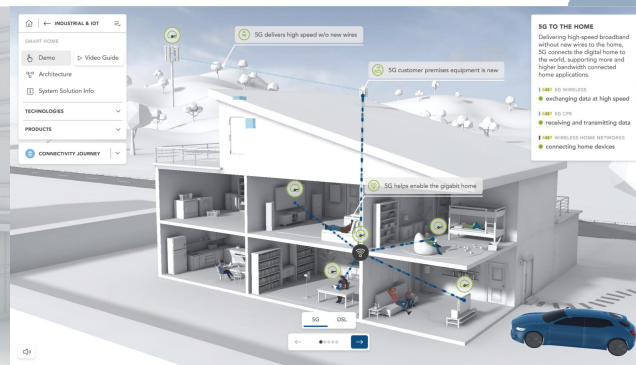
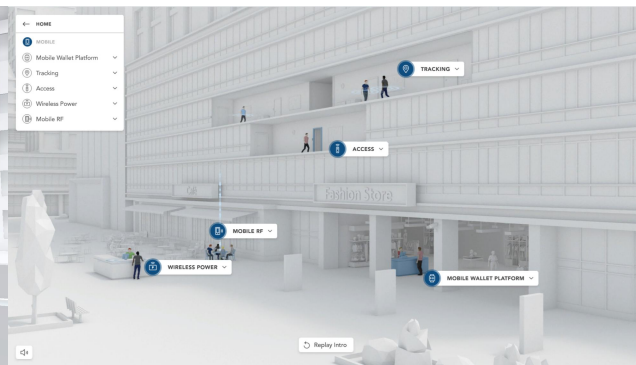
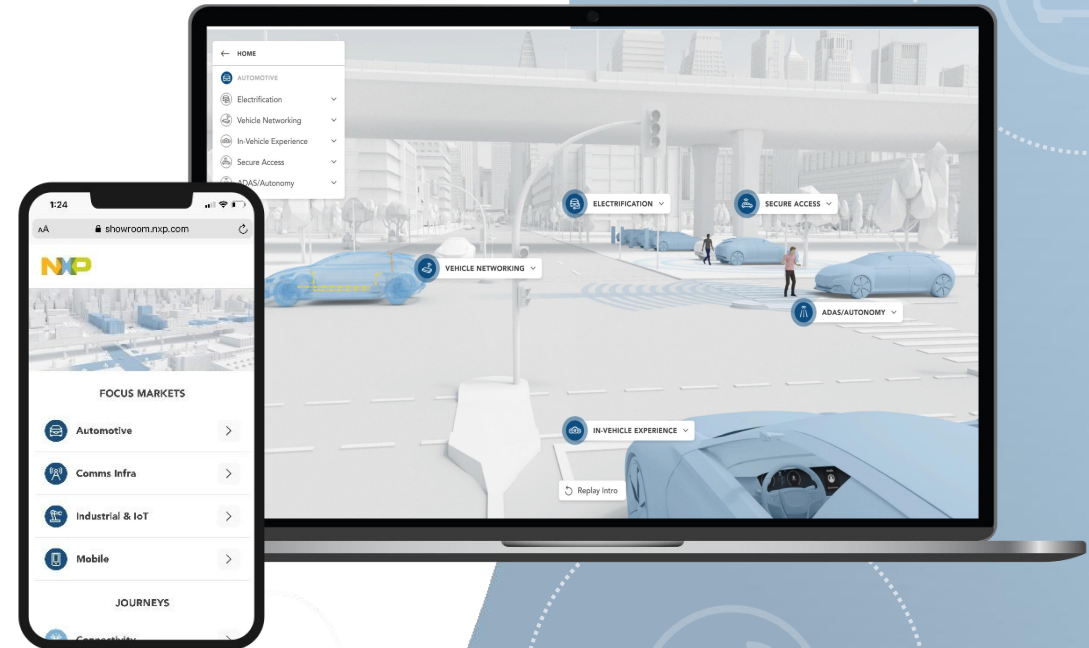

SHOWROOM.NXP.COM

WELCOME TO FOLLOW NXP AT SOCIAL PLATFORMS



欢迎您关注「恩智浦微招聘」公众号
及时获取恩智浦“芯”职位及员工
活动相关资讯



关注NXP客栈公众号，查看恩
智浦最新官方资讯及技术材料

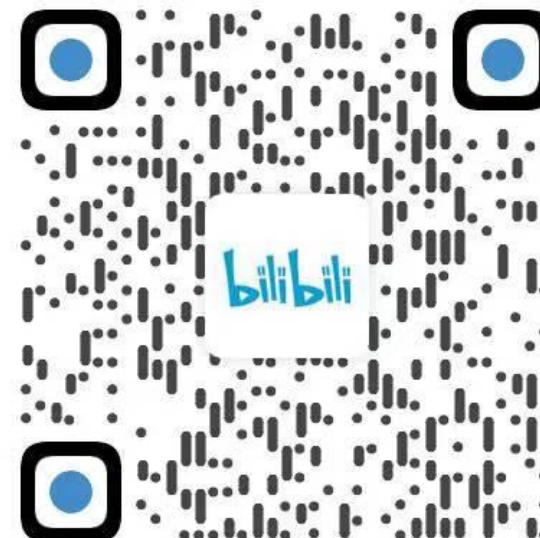

关注恩智浦B站官方账号，观
看恩智浦最新技术视频



Q&A



SECURE CONNECTIONS
FOR A SMARTER WORLD