

# NXP DSC DESIGNED FOR DIGITAL POWER CONVERSION APPLICATIONS

Richy Ye  
Systems Engineering Manager, Edge Processing BL

DECEMBER 2021



SECURE CONNECTIONS  
FOR A SMARTER WORLD

PUBLIC

NXP, THE NXP LOGO AND NXP SECURE CONNECTIONS FOR A SMARTER WORLD ARE TRADEMARKS OF NXP B.V.  
ALL OTHER PRODUCT OR SERVICE NAMES ARE THE PROPERTY OF THEIR RESPECTIVE OWNERS. © 2020 NXP B.V.





# Contents

- Benefits of digital controlled power conversion system
- DSC highlighted features for digital power applications
- Typical digital power use case introduction

# Benefits of Digital Controlled Power Conversion System

---



SECURE CONNECTIONS  
FOR A SMARTER WORLD

PUBLIC

NXP, THE NXP LOGO AND NXP SECURE CONNECTIONS FOR A SMARTER WORLD ARE TRADEMARKS OF NXP B.V.  
ALL OTHER PRODUCT OR SERVICE NAMES ARE THE PROPERTY OF THEIR RESPECTIVE OWNERS. © 2020 NXP B.V.

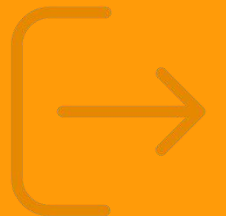

# DIGITAL VS. ANALOG CONTROL IN POWER CONVERSION SYSTEM

## Analog control

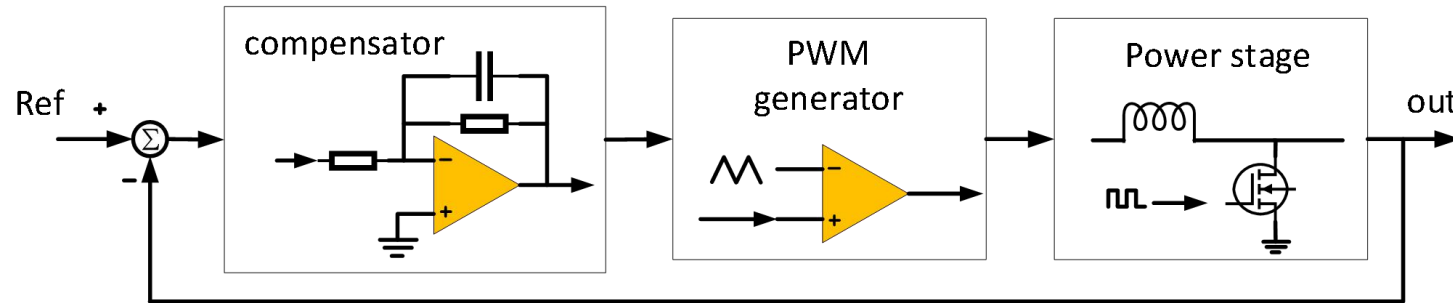

## Digital control

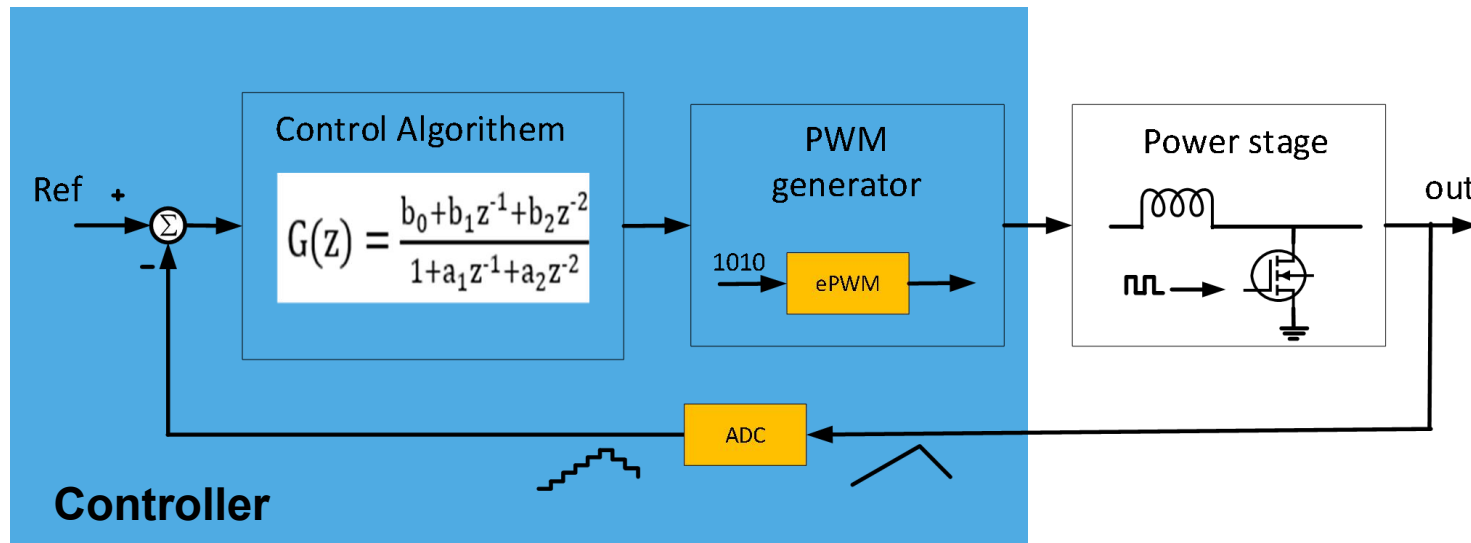

Digital control depends on translation of primary measurements of analogue signals into digital values, then the control is hardware independent.

# BENEFITS OF DIGITAL CONTROL

## *Improved flexibility*

- ✓ Easy customization
- ✓ Easy to update
- ✓ Easy to implement adaptive control and nonlinear control
- ✓ Suitable for various topologies

## *High efficiency and power density*

- ✓ According to line and load change, intelligently adjust the power stage operation to optimize efficiency in real time
- ✓ Smooth automatic switching between digital and analog control in one controller can improve standby efficiency

## *Cost effective*

- ✓ Integrated control hardware, fewer devices can perform more complex functions
- ✓ future update without board change

## *Smart and Reliable*

- ✓ Monitoring provides powerful protection for power system
- ✓ Energy internet, integrate the communication function with the power part



# DSC Highlighted Features for Digital Power Applications

---



SECURE CONNECTIONS  
FOR A SMARTER WORLD

PUBLIC

NXP, THE NXP LOGO AND NXP SECURE CONNECTIONS FOR A SMARTER WORLD ARE TRADEMARKS OF NXP B.V.  
ALL OTHER PRODUCT OR SERVICE NAMES ARE THE PROPERTY OF THEIR RESPECTIVE OWNERS. © 2020 NXP B.V.

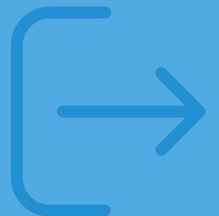

# DSC HIGHLIGHTED FEATURES FOR DIGITAL POWER APPLICATIONS

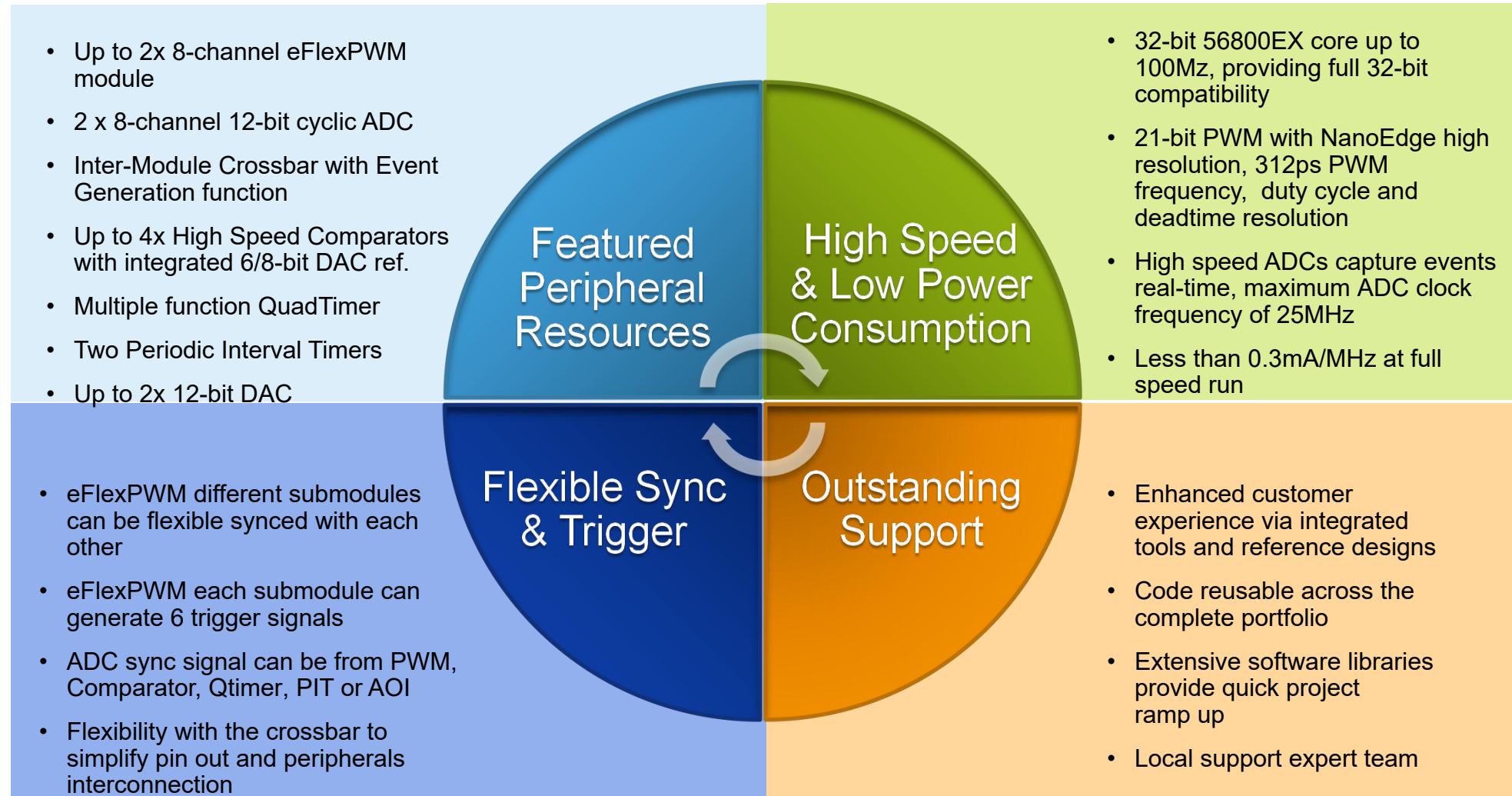

# 56800EX CORE ARCHITECTURE

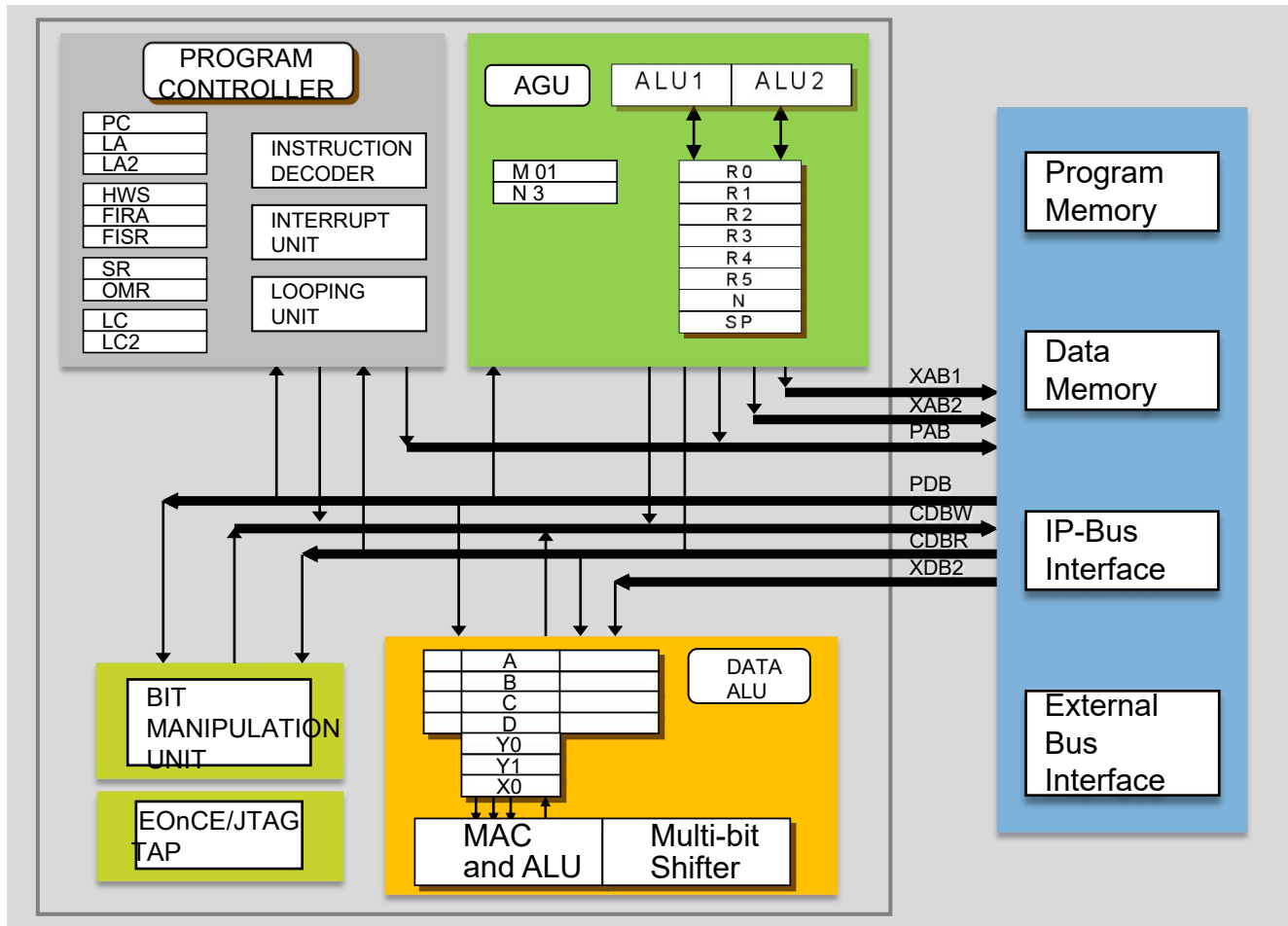

## Program Controller (PC)

- Hardware loop support
- Nested Interrupt, priority control

## Address Generation Unit (AGU)

- All registers have shadowed registers, effectively reduce context save/restore time during exception

## Bit Manipulation (BMU):

- New bit manipulation instr. BFSC

## Arithmetic Logic Unit (ALU):

- single-cycle 32 x 32-bit -> 64-bit MAC
- 32-bit fractional and integer arithmetic
- Logic multi-bit shifter
- Bit-reverse addressing mode, supporting FFT

## Bus architecture customized for DSP applications

- 1x 16bit Instr. + 1x 32bit data + 1x 16bit data bus
- Concurrent instruction fetches
- Dual data accesses in single cycle



# EFLEXPWM – 312PS HIGH RESOLUTION PWM

- 312ps resolution, suitable for digital power applications
- Flexible PWM control and multiple modes
  - Center, edge-aligned, and asymmetrical PWMs
  - Complementary PWM pairs
  - Phase shifted & double switching PWM outputs
  - Independent control of both edges of each PWM output
  - Full and half cycle reload capability
  - Individual software control for each PWM output
- Synchronization & Trigger
  - Support for synchronization to external hardware or other PWM
  - Multiple output trigger events can be generated per PWM cycle
- Safety
  - Fault inputs can be assigned to control multiple PWM outputs
  - Programmable filters for fault inputs
  - Fault automatic clearing
  - Independent top and bottom deadtime insertion
- Multiple functions support
  - Channels not used for PWM generation can be used for input capture functions, dual independent capture engines

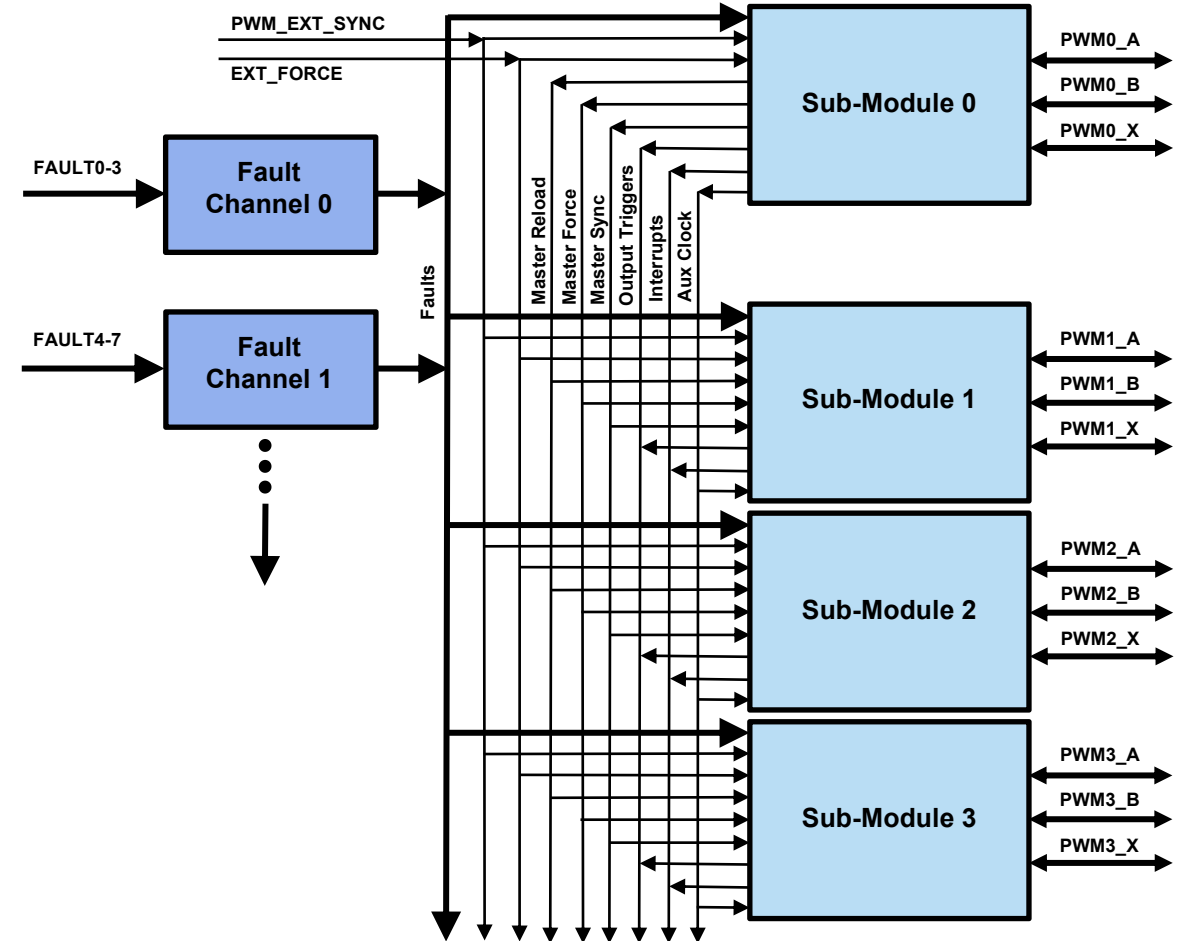

# 12-BIT HIGH SPEED CYCLIC ADC

- High input impedance, suitable for current sensing
- Max. 300ns conversion rate, up to 6.67 MSPS when two ADC work simultaneously (parallel mode)
- Flexible trigger mode include once, triggered or loop scan
- Can be synchronized to other peripherals by internal Crossbar, such as the PWM
- Improved Accuracy
  - Integrated PGA (x1, x2, x4) for small signal detection
  - Optional sample correction by pre-programmed offset
  - Support single-end and differential mode
- Multiple Functions
  - Optional interrupts at end of scan if there's an out of high/low limit or there is a zero-crossing event

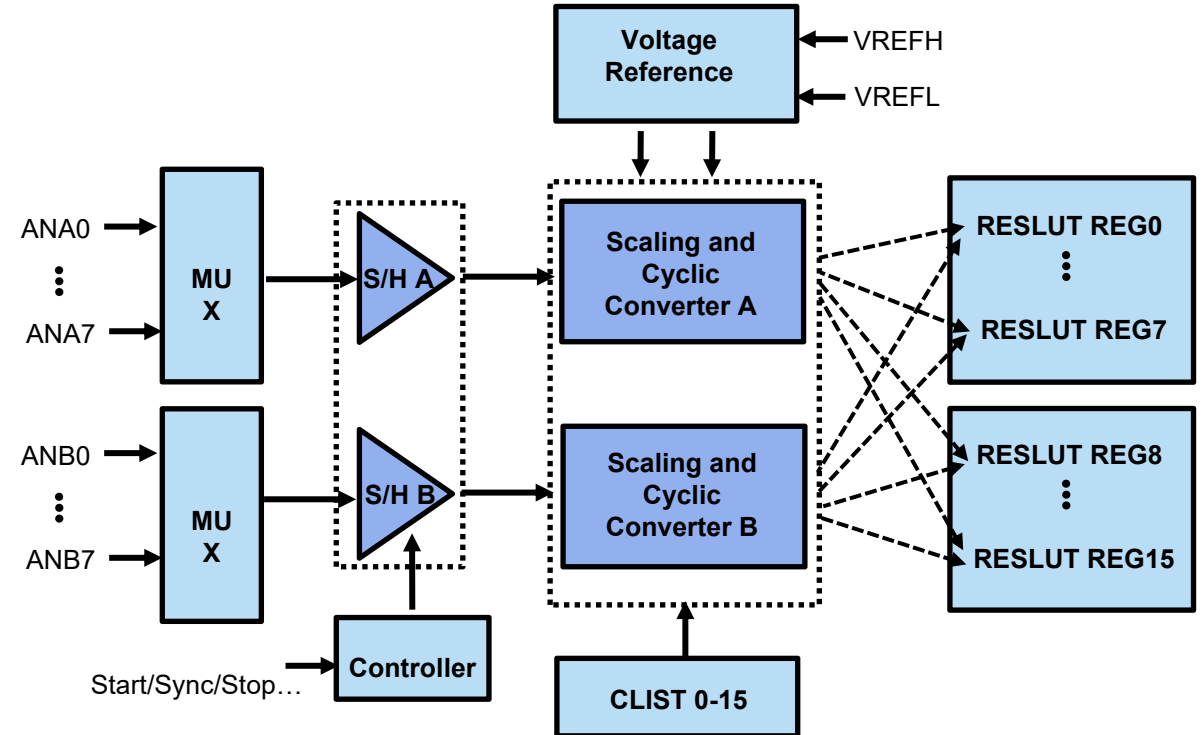

# MULTI-MODE OPAMP

- 8MHz GBP, suitable for fast and accurate voltage and current sensing in power conversion and motor control applications
- Suitable for low side detection, output rail-to-rail
- work in three modes:
  - Op-amp mode
  - PGA mode (Gain 2/4/8/16)
  - Follower mode
- Output directly connect to ADC and ACMP input

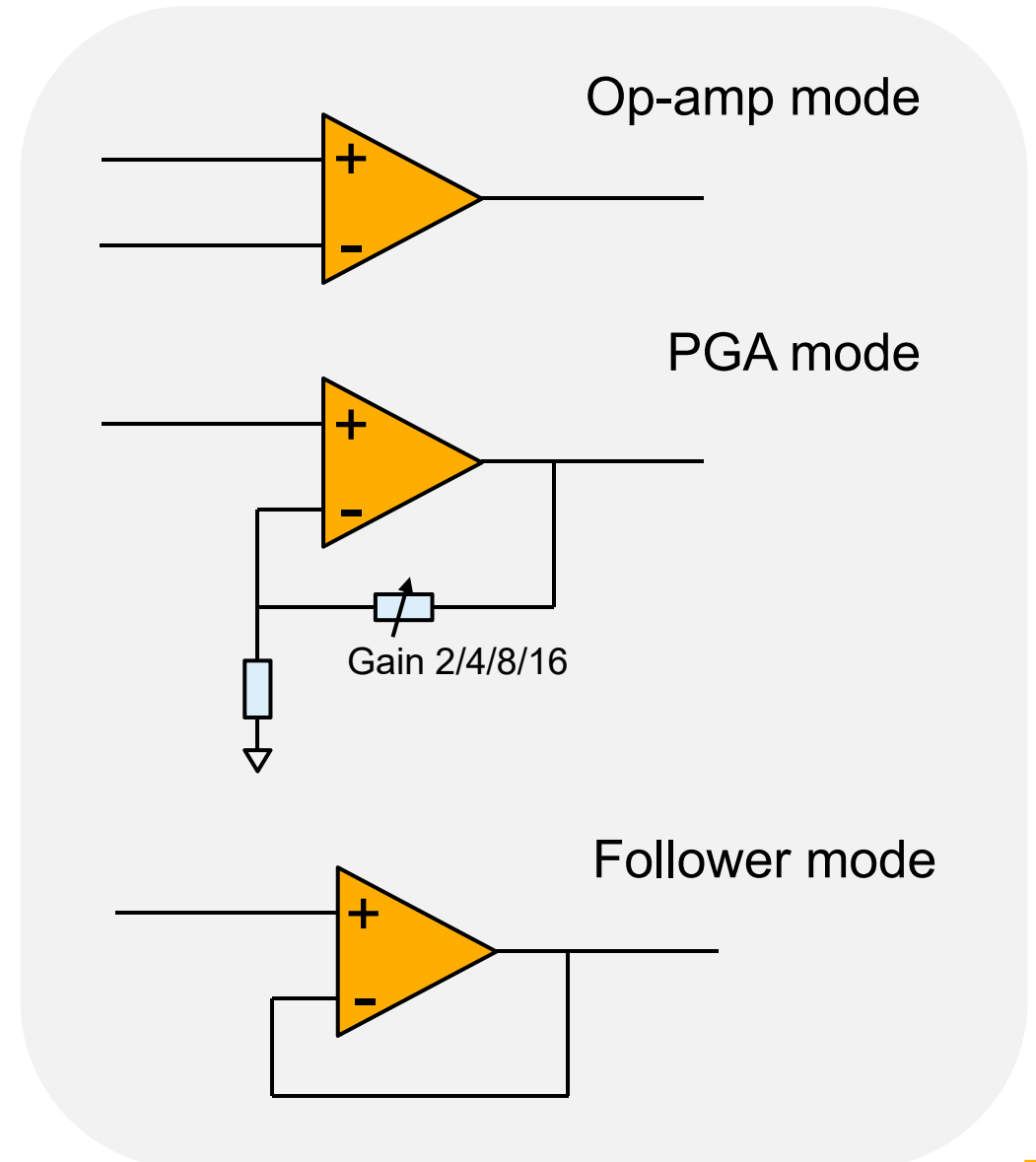

# HSCMP /W 6/8-BIT REFERENCE DAC

- Multiple analog comparators with integrated programmable DAC references
- selectable internal hysteresis levels
- Full rail-to-rail comparison range
- Selectable input source includes external pins and internal 8-bit or 12-bit DACs and OPAMP out
- Comparator output may be:
  - Sampled
  - Windowed (ideal for certain PWM zero-crossing-detection applications)
  - Digitally Filtered
- External hysteresis can be used
- Integrated DAC is powered down to conserve power when it isn't used

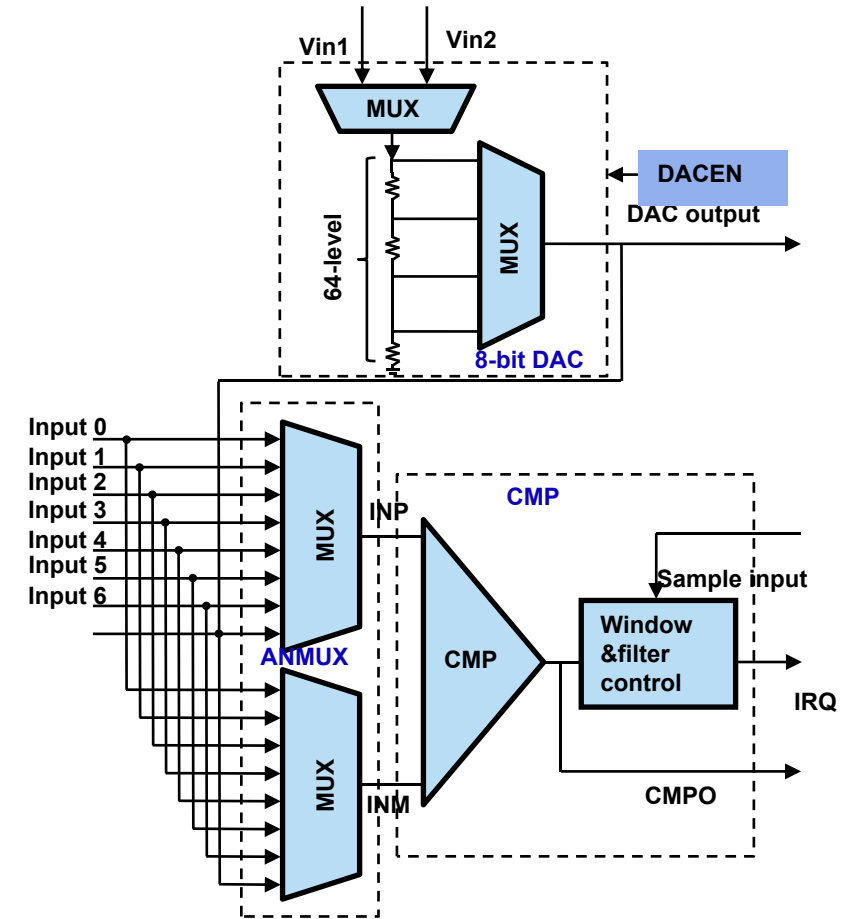

# 12-BIT DAC

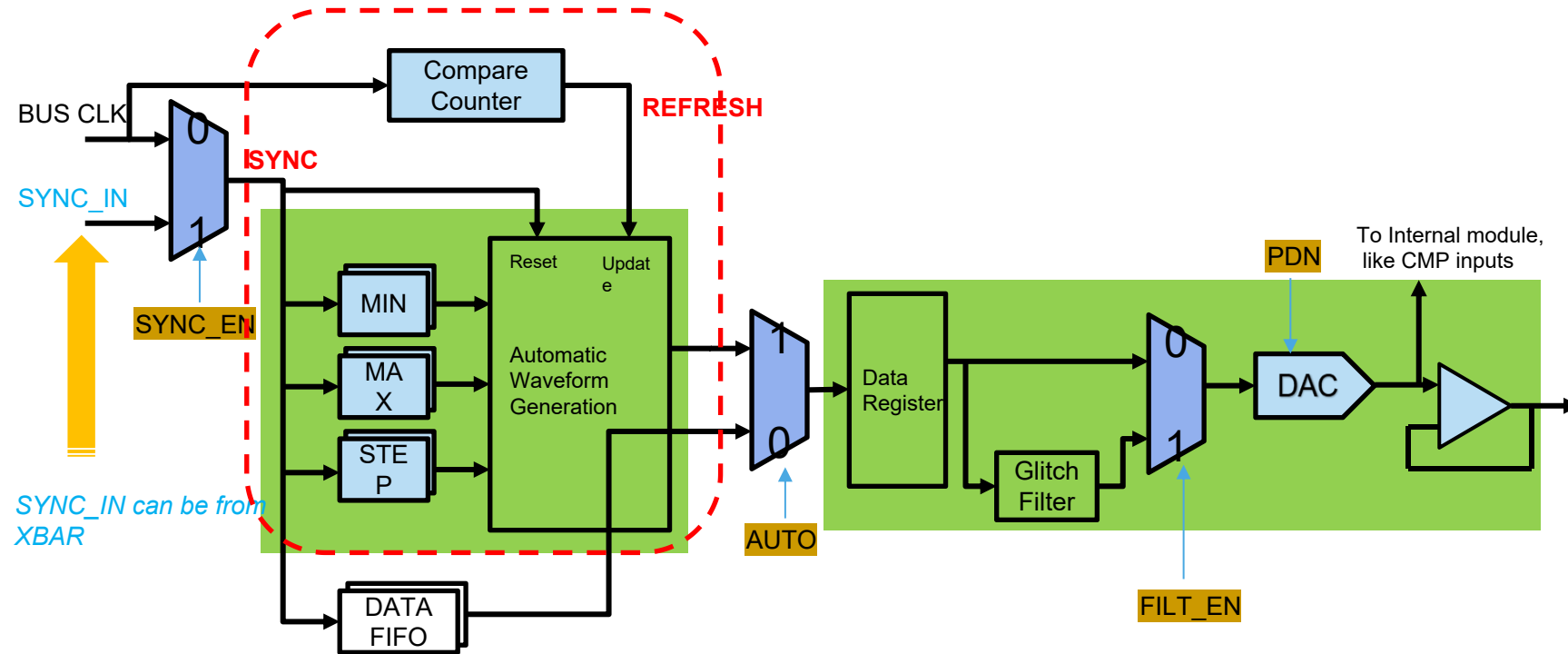

- Automatic waveform generation:
  - MAX/MIN/STEP are buffered and updated with sync signal
  - Sync signal reset the automatic waveform to its new start point defined by new MAX/MIN
  - Configurable update rate
  - Automatic waveform can hold its last value until the next active edge of SYNC\_IN

# CONFIGURABLE LOGIC – XBAR + EVENT GENERATOR (EVTG)

- XBAR
  - A switch matrix with dozens of inputs and outputs
  - Each output can choose any input
  - The inputs and outputs are connected to peripherals or package pins
- EVTG
  - Each has four input A,B,C and D and two outputs
  - Each has two groups of AOI to generate two combinational expressions.
  - Each has one flexible flipflop that can be configured as RS, D-FF,T-FF, JK-FF and Latch, etc.

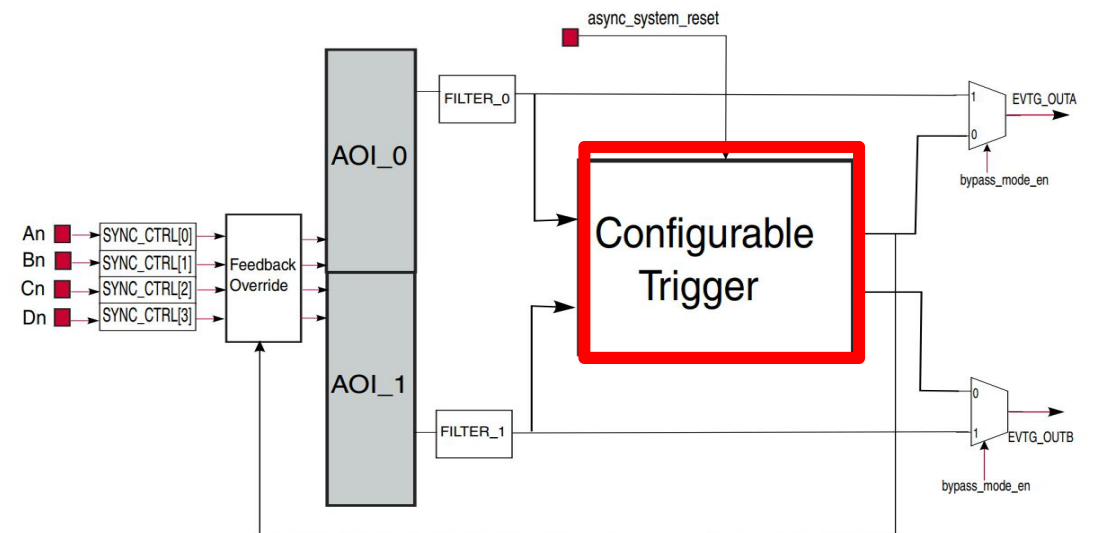
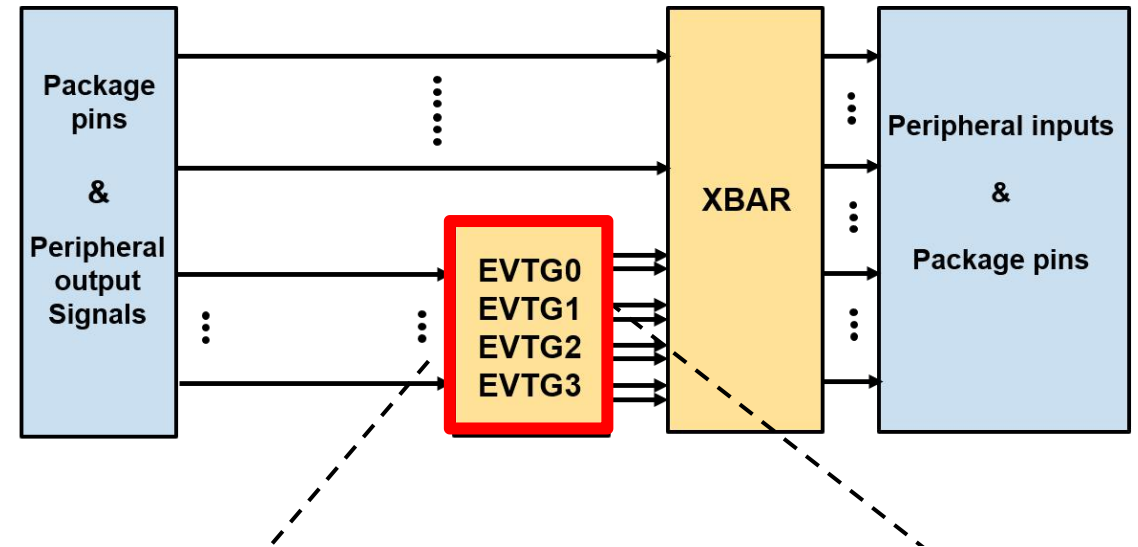

# FLASH SWAP

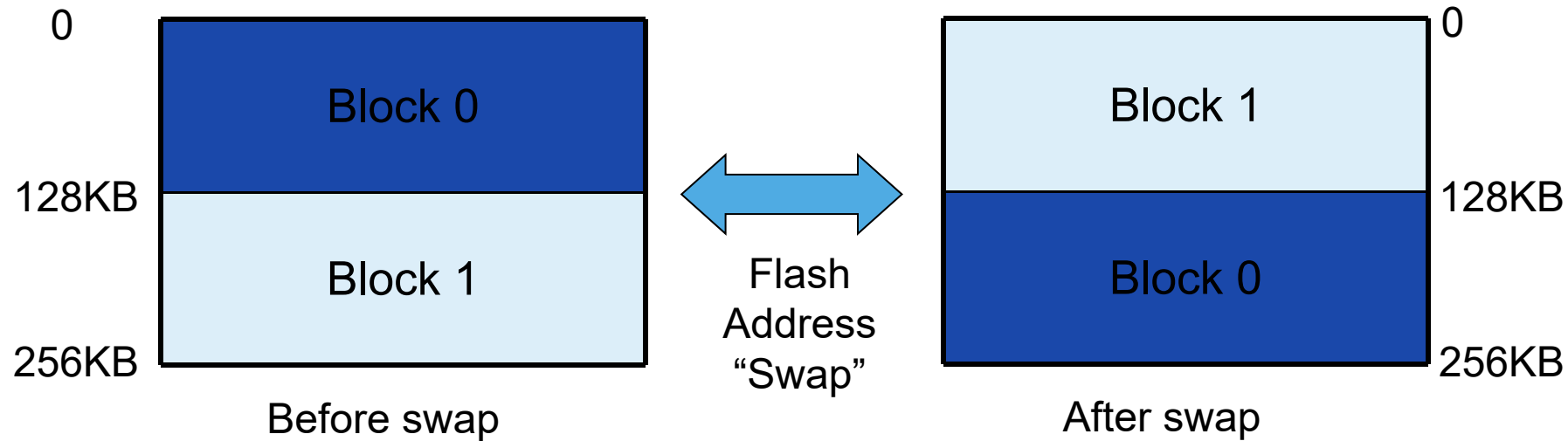

- Two Flash blocks
- User can execute from block 0 while re-programming block 1
- When block 1 is ready for execution, user completes the swap process by executing a SWAP command and a reset
- The addresses of block 0 and block 1 exchanges after reset. Program now executes in block 1 because it is mapped to address range which starts from 0

# CRYPTO ENGINE – DSASS

- **DSASS** = **D**igital **S**ignature **A**lgorithm **S**ecurity **S**ubsystem
- DSASS contains HW realization of below algorithms:
  - Elliptical Curve Cryptography (ECC) based digital signature authentication
  - SHA256
  - True random number generator (TRNG)
- Complete APIs and example codes to utilize the crypto capability

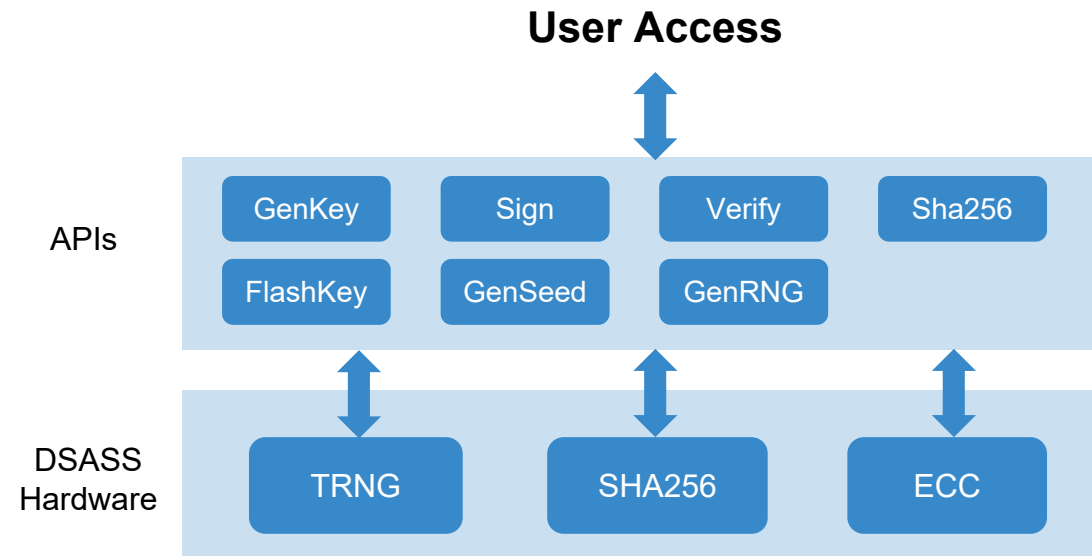



# Typical Digital Power Use Cases Introduction

---



SECURE CONNECTIONS  
FOR A SMARTER WORLD

PUBLIC

NXP, THE NXP LOGO AND NXP SECURE CONNECTIONS FOR A SMARTER WORLD ARE TRADEMARKS OF NXP B.V.  
ALL OTHER PRODUCT OR SERVICE NAMES ARE THE PROPERTY OF THEIR RESPECTIVE OWNERS. © 2020 NXP B.V.



# PEAK CURRENT CONTROL

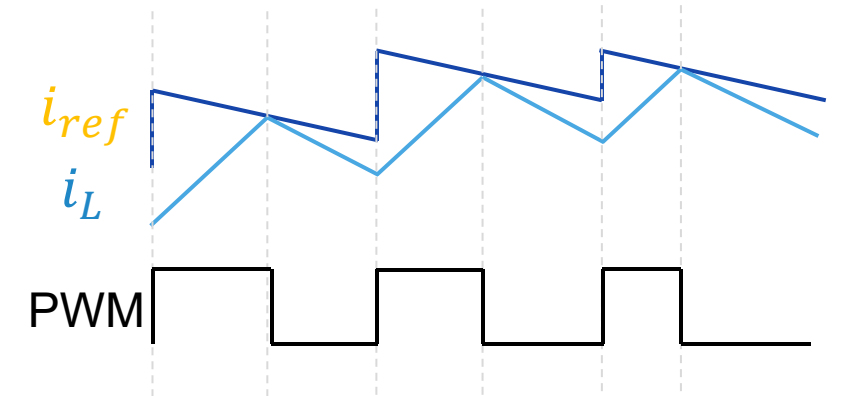
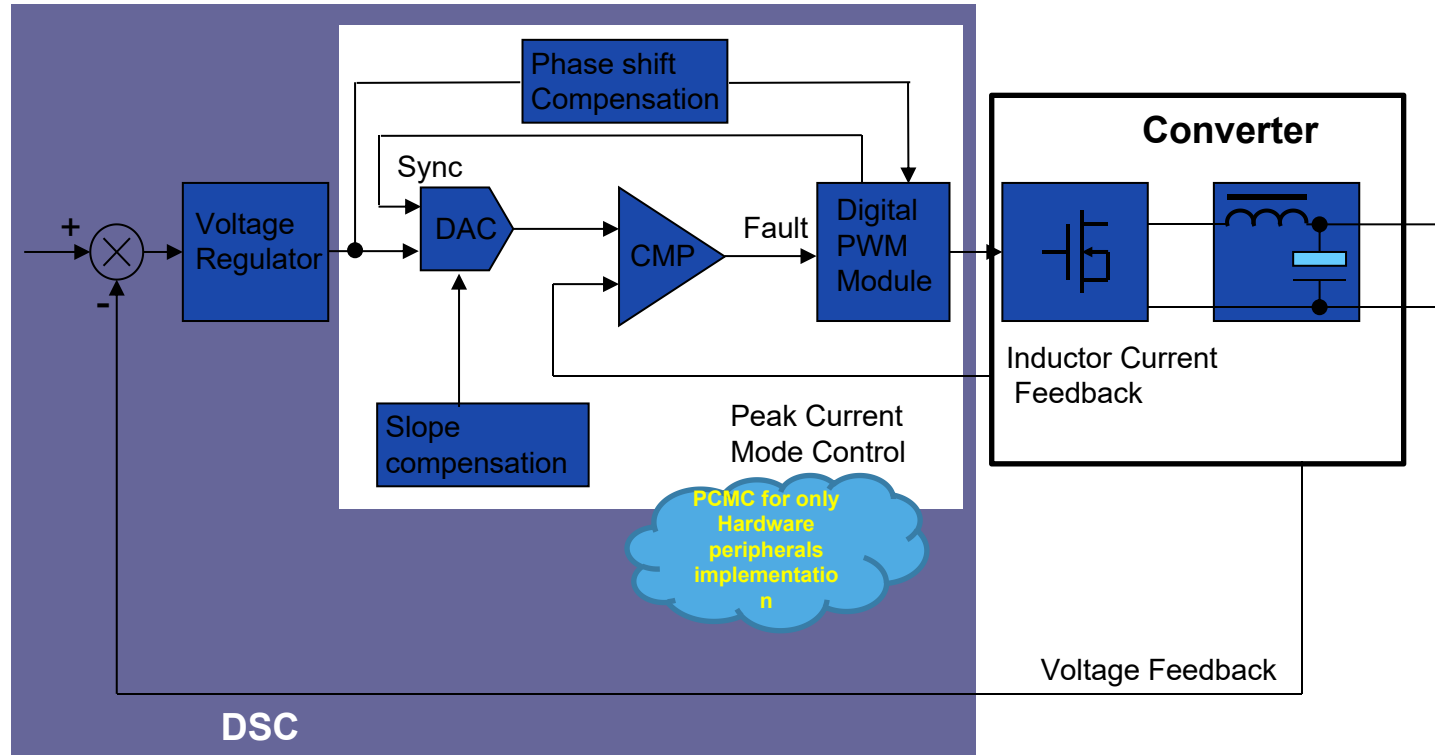

- Window Mode Comparator** → Only take effect when PWM is on for more reliable
- 12 Bit High Resolution DAC** → Slop compensation with adjustable slow rate
- PWM Signal Synchronization** → CBC Peak Value control (cooperate with AOI to achieve minimum duty cycle control)

Fully hardware realization solution, which brings larger bandwidth and elimination of CPU overhead. Now CPU can focus on voltage loop and other staffs, like housekeeping.

# PEAK CURRENT CONTROL MODE(PCCM) PSFB

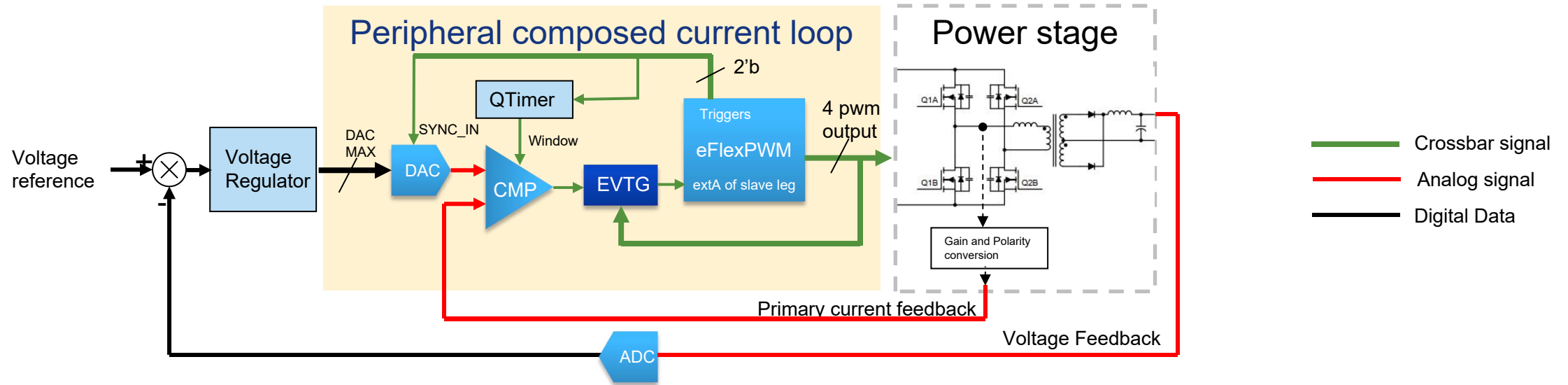

With the presence of EVTG and XBAR, the status and phase of the bridge legs can be monitored to avoid maloperation (e.g. multiple switches of slave leg within half of the PWM period).

# PWM GENERATION FOR LEADING AND LAGGING LEGS CONTROL

EVTG flip flop works at Set/Reset mode. Master leg (Q1A&Q1B) is controlled by SM0 of eFlexPWMA, where fixed 50% duty complementary waveforms are applied. Slave leg(Q2A&Q2B) is controlled by SM1 of eFlexPWMA, the SM1 outputs are from its EXTA input, which is fed by EVTG output. With the convenience that both PWMA output signals and its trigger signals can be routed to XBAR inputs simultaneously, the Reset and Set input signals of EVTG can be realized so that slave leg is fully synchronized with master leg and also controlled by coil current.

The control loop of primary coil current is realized without CPU overhead at all, which means high dynamic response can be achieved. Meanwhile, the outer voltage loop and other house keeping tasks are flexibly realized by firmware. This control method combines the advantages of pure analog control loop and digital MCU control, where EVTG plays an important role.

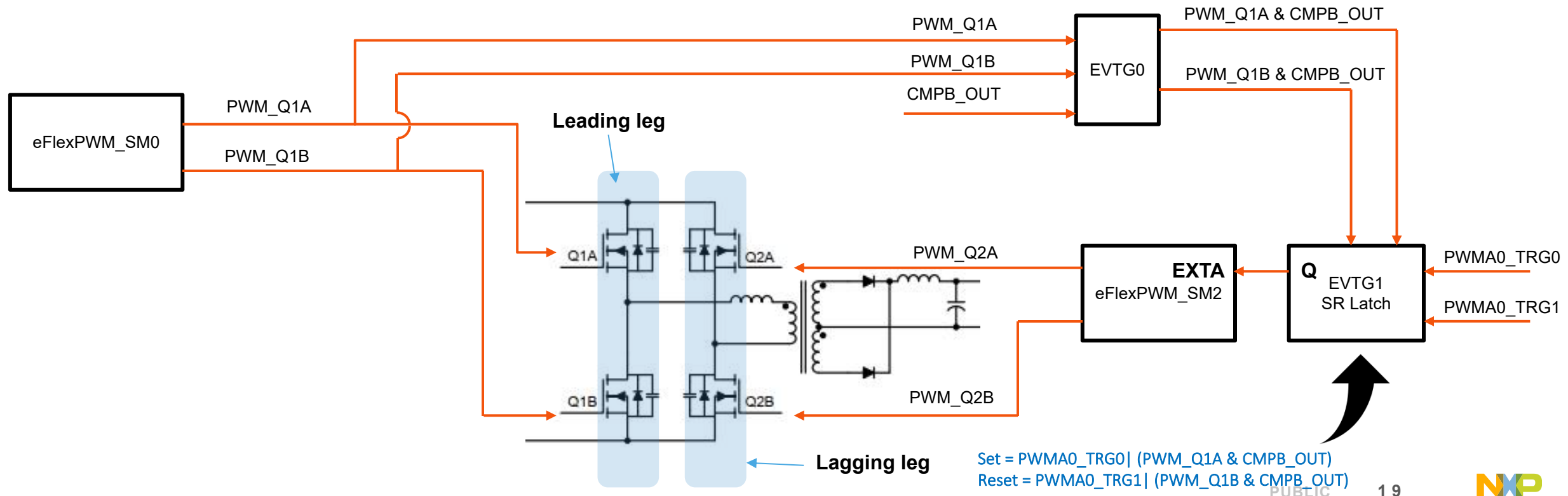

# SOFT-START PROCESS EXAMPLE

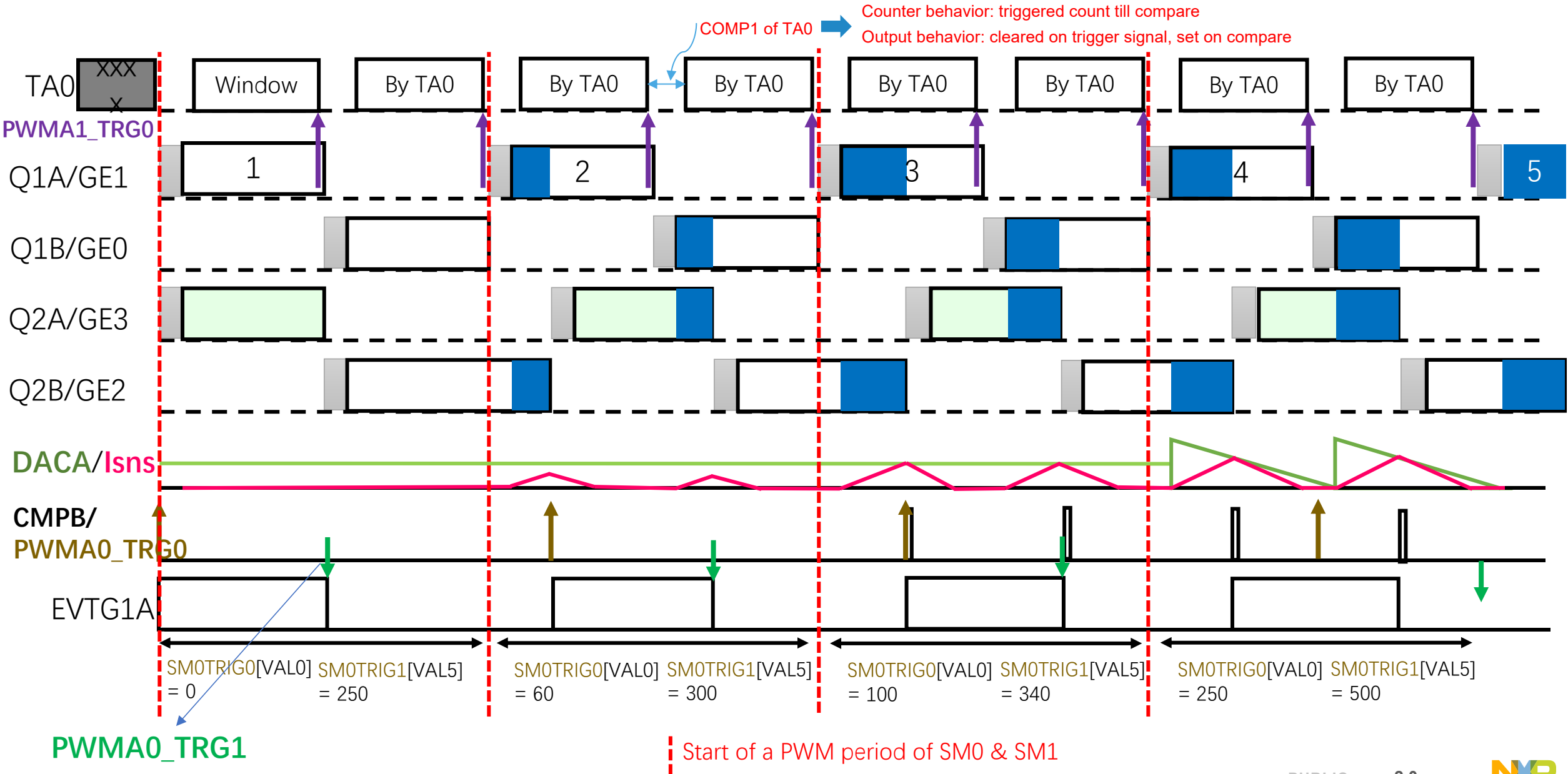

# AVERAGE CURRENT CONTROLLED LLC

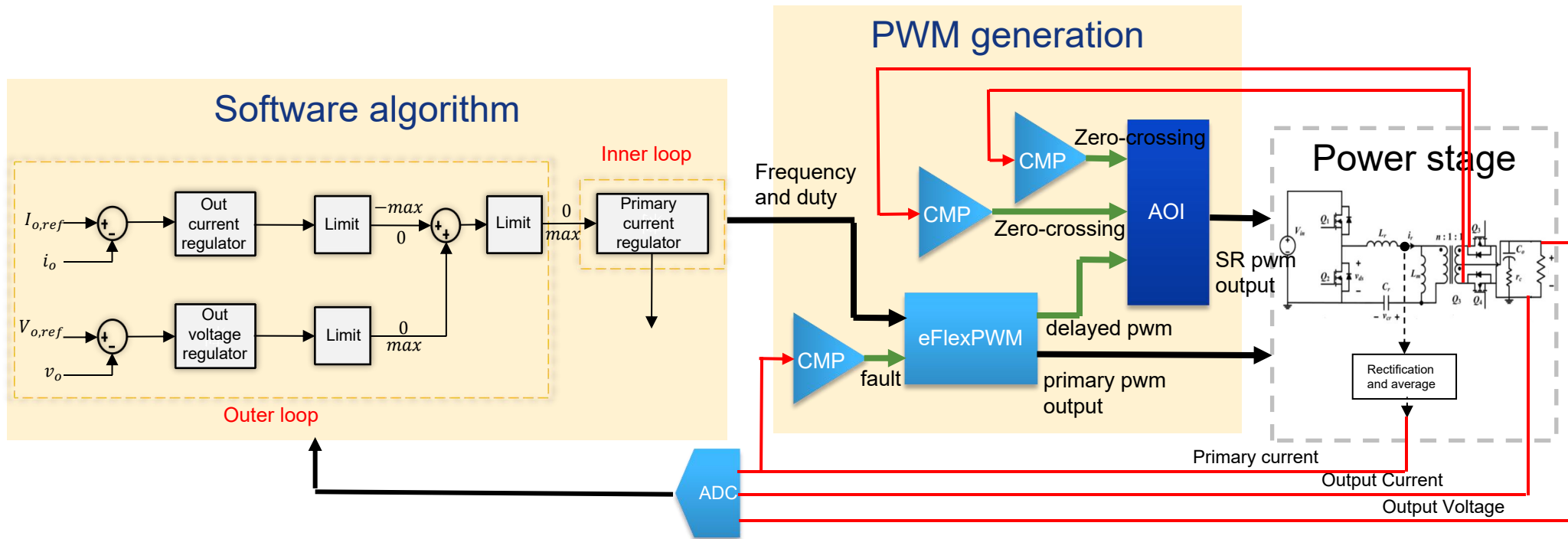

- Flexible software algorithm: concurrent output loop smooth transition to achieve constant output voltage and overload current limiting, smooth transition between PFM, PWM and burst mode
- Precise SR control
- Hardware fault protection

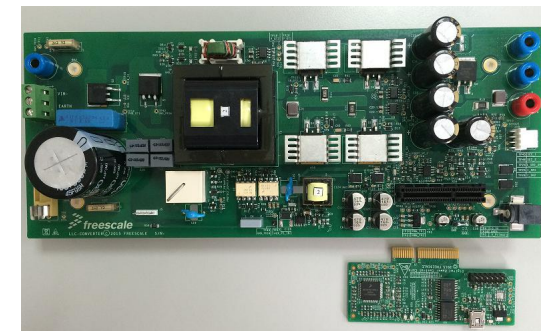

# AUTOMATIC MODULATION MODES SWITCH

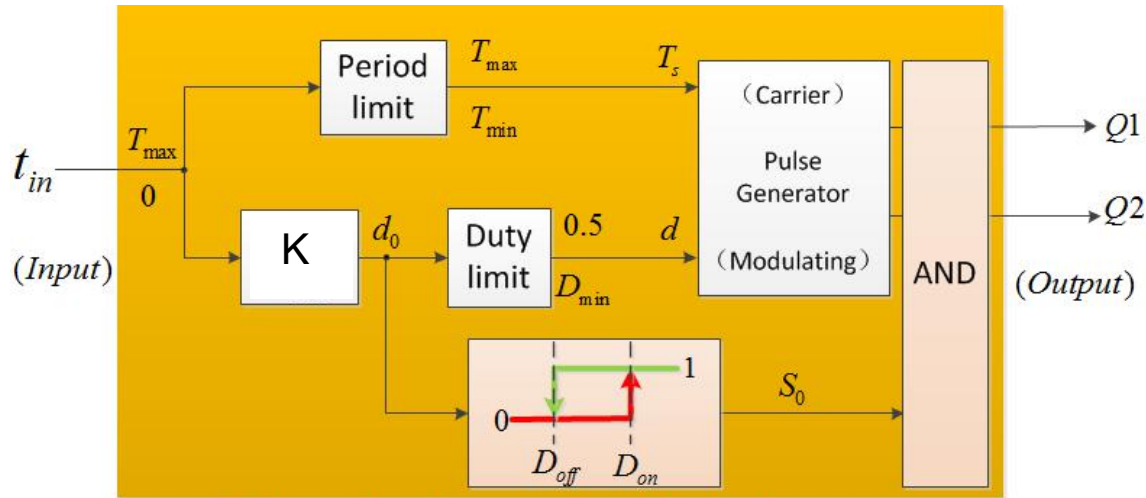

Drive signal generator block diagram

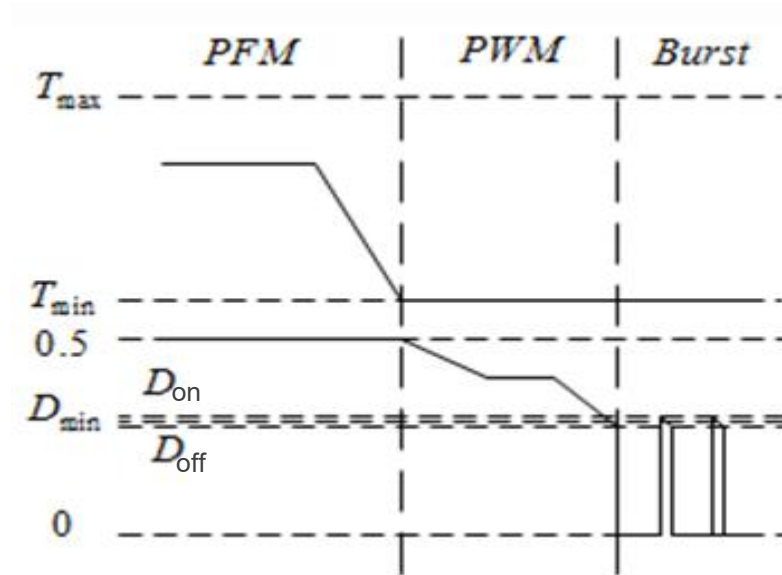

- Mode 1: PFM

$$T_{\min} \leq t_{in} \leq T_{\max} \quad \rightarrow \quad T_s = t_{in}, d = 0.5$$

- Mode 2: PWM

$$KD_{off} < t_{in} < T_{\min} \quad \rightarrow \quad T_s = T_{\min}, D_{\min} < d < 0.5$$

- Mode 3: Burst mode

$$t_{in} < KD_{off} \quad \leftrightarrow \quad d_0 < D_{off}$$

$$d_0 > D_{on} \quad \rightarrow \quad S_0 = 1 \text{ Burst on}$$

$$d_0 < D_{off} \quad \rightarrow \quad S_0 = 0 \text{ Burst off}$$

# CHARGE CURRENT CONTROLLED LLC

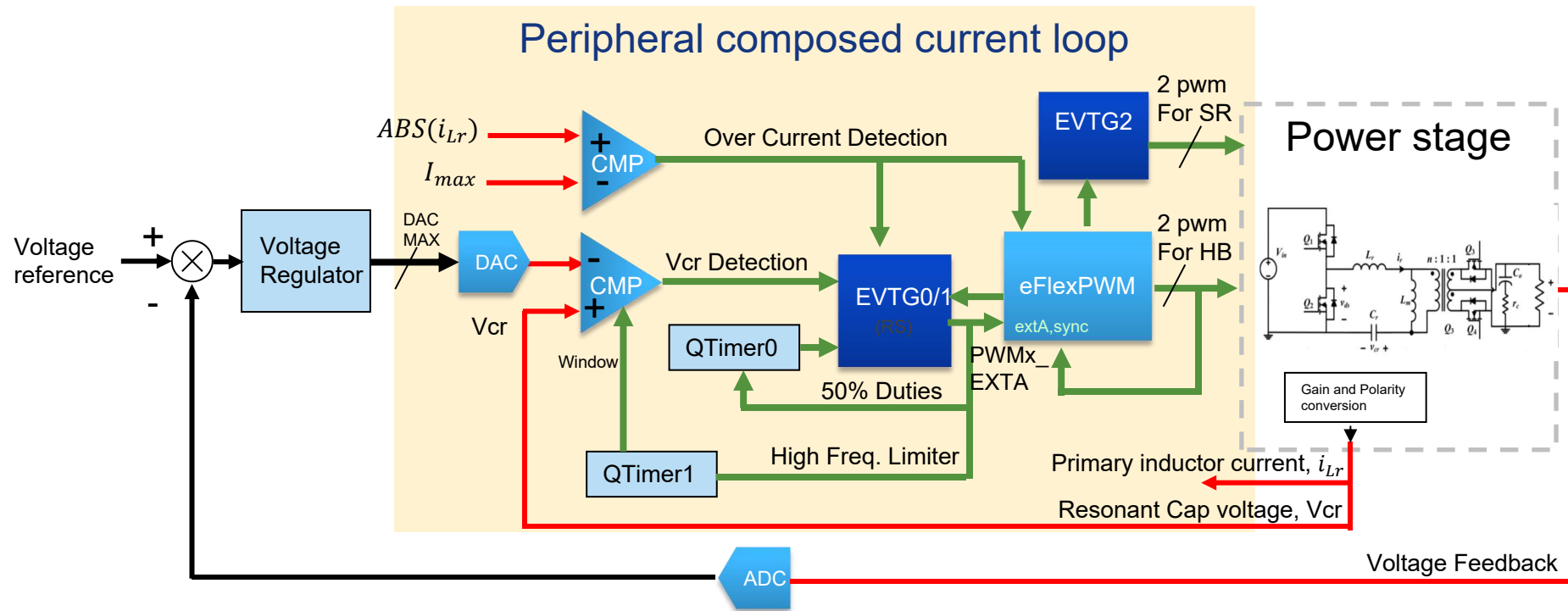

- Rich and flexible peripherals and flexible signal interconnection promise the complex control requirements:
  - Maximum current limit
  - 50% duty cycle
  - High/low frequency limit
  - Ramp compensation



# INNOVATIVE METHOD FOR STANDBY EFFICIENCY IMPROVEMENT

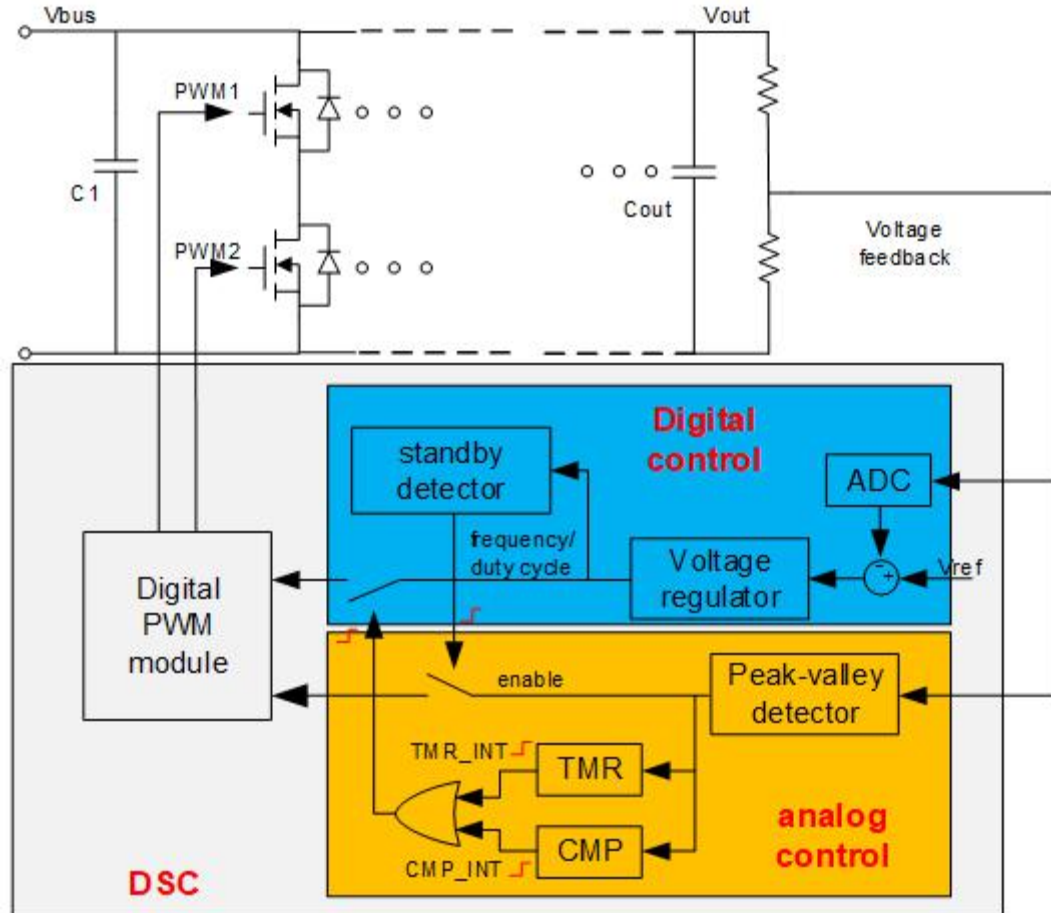

Hybrid control in one DSC to minimize the controller power consumption during system standby mode.

- In digital control mode: core and memory of the controller are powered up, the PWM signal are adjusted according to software algorithm
- In analog control mode: core and memory of the controller are powered off, the controller built-in peripherals constitute the controller
- Smooth and automatic switch between two mode
  - In digital control mode, the algorithm can judge whether to enter the analog mode
  - In analog mode, specific event can be configured to wake the controller

# INNOVATIVE METHOD FOR STANDBY EFFICIENCY IMPROVEMENT – EXAMPLE

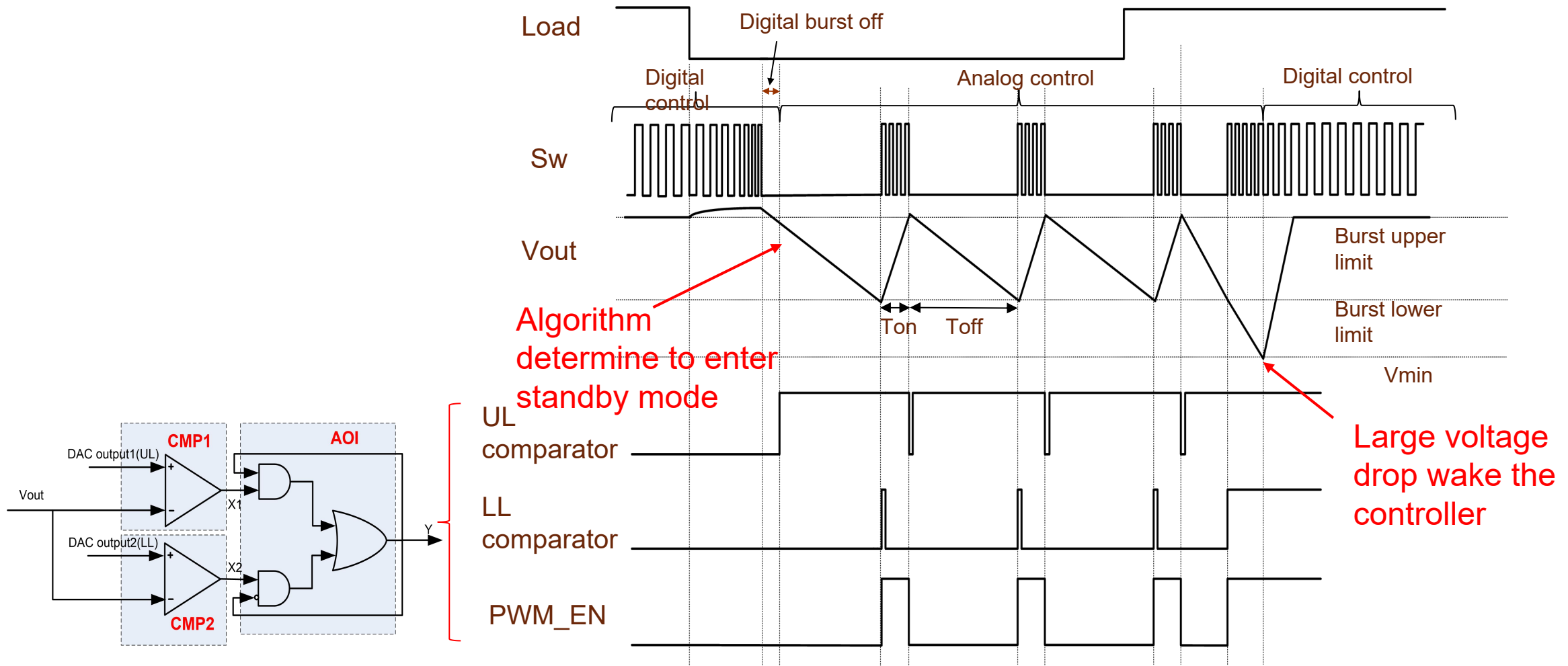

# WRAP-UP

## Through this session, you already learned:

- Benefits of digital controlled power conversion system
- DSC highlighted features designed for digital power applications:
  - 56800EX core
  - eFlexPWM
  - Analog peripherals: High speed cyclic ADC, multi-mode OPAMP, 12-bit DAC with automatic waveform generation, HSCMP with reference DAC
  - XBAR and EVTG
  - Flash swap
  - Crypto engine
- Typical digital power use cases:
  - PCCM PSFB DC/DC converter
  - Average current controlled LLC DC/DC converter
  - Charge current controlled LLC DC/DC converter
  - Standby system efficiency improvement

# NXP WECHAT AND RECRUITMENT

欢迎关注公司官微NXP客栈



欢迎关注恩智浦微招聘，了解更多职位信息



参与恩智浦2022校招，请扫码进行网申



# Q&A



SECURE CONNECTIONS  
FOR A SMARTER WORLD